

**INSTALLATION, OPERATION,
AND MAINTENANCE MANUAL**
WITH PARTS LIST



PAH SERIES® PUMP

MODEL
PAH10A60C-B

GORMAN-RUPP PUMPS

www.grpumps.com

Register your new
Gorman-Rupp pump online at
www.grpumps.com

Valid serial number and e-mail address required.

RECORD YOUR PUMP MODEL AND SERIAL NUMBER

Please record your pump model and serial number in the spaces provided below. Your Gorman-Rupp distributor needs this information when you require parts or service.

Pump Model: _____

Serial Number: _____

TABLE OF CONTENTS

INTRODUCTION	PAGE I – 1
SAFETY - SECTION A	PAGE A – 1
INSTALLATION – SECTION B	PAGE B – 1
Pump Dimensions	PAGE B – 1
PREINSTALLATION INSPECTION	PAGE B – 1
POSITIONING PUMP	PAGE B – 2
Lifting	PAGE B – 2
Mounting	PAGE B – 2
AIR COMPRESSOR ELECTRICAL CONNECTIONS	PAGE B – 2
SUCTION AND DISCHARGE PIPING	PAGE B – 3
Materials	PAGE B – 3
Line Configuration	PAGE B – 3
Connections to Pump	PAGE B – 3
Gauges	PAGE B – 3
SUCTION LINES	PAGE B – 3
Fittings	PAGE B – 3
Strainers	PAGE B – 3
Sealing	PAGE B – 3
Suction Lines In Sumps	PAGE B – 4
Suction Line Positioning	PAGE B – 4
DISCHARGE LINES	PAGE B – 4
Siphoning	PAGE B – 4
Valves	PAGE B – 5
ALIGNMENT	PAGE B – 5
Coupled Drives	PAGE B – 5
COLD WEATHER INSTALLATION	PAGE B – 6
OPERATION – SECTION C	PAGE C – 1
PRIMING	PAGE C – 1
STARTING	PAGE C – 1
Rotation	PAGE C – 1
Priming	PAGE C – 1
OPERATION	PAGE C – 1
Leakage	PAGE C – 1
Liquid Temperature And Overheating	PAGE C – 2
Strainer Check	PAGE C – 2
Pump Vacuum Check	PAGE C – 2
STOPPING	PAGE C – 2
PERIODIC CHECKS	PAGE C – 3
Seal Cavity and Bearing Lubrication	PAGE C – 3
Bearing Temperature Check	PAGE C – 3
Air Compressor	PAGE C – 3
COLD WEATHER PRESERVATION	PAGE C – 3
TROUBLESHOOTING – SECTION D	PAGE D – 1

TABLE OF CONTENTS
(continued)

PREVENTIVE MAINTENANCE	PAGE D – 3
PUMP MAINTENANCE AND REPAIR - SECTION E	PAGE E – 1
STANDARD PERFORMANCE CURVE	PAGE E – 1
PARTS LISTS:	
Pump Model	PAGE E – 3
Repair Rotating Assembly	PAGE E – 5
Air Compressor Assembly	PAGE E – 7
Priming Chamber Kit	PAGE E – 8
Priming Chamber Assembly	PAGE E – 9
Air Compressor Wiring Schematic	PAGE E – 10
Venturi Assembly	PAGE E – 11
PUMP AND SEAL DISASSEMBLY AND REASSEMBLY	PAGE E – 12
Priming Chamber Removal And Disassembly	PAGE E – 13
Discharge Check Valve Removal and Disassembly	PAGE E – 13
Pump Casing and Wear Ring Removal	PAGE E – 13
Impeller and Wear Ring Removal	PAGE E – 13
Seal Removal	PAGE E – 14
Air Compressor Removal	PAGE E – 14
Separating Rotating Assembly From Power Source	PAGE E – 14
Shaft and Bearing Removal and Disassembly	PAGE E – 15
Shaft and Bearing Reassembly and Installation	PAGE E – 16
Securing Rotating Assembly to Power Source	PAGE E – 17
Seal Reassembly and Installation	PAGE E – 17
Impeller Installation	PAGE E – 19
Pump Casing and Wear Ring Installation	PAGE E – 19
Discharge Check Valve Assembly and Installation	PAGE E – 20
Priming Chamber Assembly And Installation	PAGE E – 20
LUBRICATION	PAGE E – 20
Seal Assembly	PAGE E – 20
Bearings	PAGE E – 20
Power Source	PAGE E – 20

INTRODUCTION

Thank You for purchasing a Gorman-Rupp pump. **Read this manual** carefully to learn how to safely install and operate your pump. Failure to do so could result in personal injury or damage to the pump.

Because pump installations are seldom identical, this manual cannot possibly provide detailed instructions and precautions for every aspect of each specific application. Therefore, it is the responsibility of the owner/installer of the pump to ensure that applications not addressed in this manual are performed **only** after establishing that neither operator safety nor pump integrity are compromised by the installation. Pumps and related equipment **must** be installed and operated according to all national, local and industry standards.

If there are any questions regarding the pump or its application which are not covered in this manual or in other literature accompanying this unit, please contact your Gorman-Rupp distributor, or The Gorman-Rupp Company:

The Gorman-Rupp Company
P.O. Box 1217
Mansfield, Ohio 44901—1217
Phone: (419) 755—1011
 or:
Gorman-Rupp of Canada Limited
70 Burwell Road
St. Thomas, Ontario N5P 3R7
Phone: (519) 631—2870

For information or technical assistance on the power source, contact the power source manufacturer's local dealer or representative.

HAZARD AND INSTRUCTION DEFINITIONS

The following are used to alert maintenance personnel to procedures which require special attention, to those which could damage equipment, and to those which could be dangerous to personnel:



Immediate hazards which WILL result in severe personal injury or death. These instructions describe the procedure required and the injury which will result from failure to follow the procedure.



Hazards or unsafe practices which COULD result in severe personal injury or death. These instructions describe the procedure required and the injury which could result from failure to follow the procedure.



Hazards or unsafe practices which COULD result in minor personal injury or product or property damage. These instructions describe the requirements and the possible damage which could result from failure to follow the procedure.

NOTE

Instructions to aid in installation, operation, and maintenance or which clarify a procedure.

SAFETY - SECTION A

This information applies to Prime Aire® Series pumps. Refer to the manual accompanying the engine or power source before attempting to begin operation.

Because pump installations are seldom identical, this manual cannot possibly provide detailed instructions and precautions for each specific application. Therefore, it is the owner/installer's responsibility to ensure that applications not addressed in this manual are performed only after establishing that neither operator safety nor pump integrity are compromised by the installation.



Before attempting to open or service the pump:

1. Familiarize yourself with this manual.
2. Shut down the engine and disconnect the positive battery cable to ensure that the pump will remain inoperative.
3. Allow the pump to completely cool if overheated.
4. Check the temperature and make sure the pump is cool before opening any covers, plates, or plugs.
5. Close the suction and discharge valves.
6. Vent the pump slowly and cautiously.
7. Drain the pump.



This pump is equipped with an automatic starting system, and is subject to automatic restart. Keep hands and clothing away from the unit to prevent injury during automatic operation. Disconnect

the positive battery cable before performing any maintenance. Failure to do so may result in serious personal injury.



Do not attempt to disengage any part of an overheated pump unit. Vapor pressure within the pump casing can eject these parts with great force when they are disengaged. Allow the pump to completely cool before servicing it.



This pump is designed to handle most non-volatile, non-flammable liquids containing specified entrained solids. Do not attempt to pump volatile, corrosive, or flammable liquids which may damage the pump or endanger personnel as a result of pump failure.



Death or serious personal injury and damage to the pump or components can occur if proper lifting procedures are not observed. Make certain that hoists, chains, slings or cables are in good working condition and of sufficient capacity and that they are positioned so that loads will be balanced and the pump or components will not be damaged when lifting. Suction and discharge hoses and piping must be removed from the pump before lifting. Lift the pump or component only as high as necessary and keep personnel away from suspended objects.



After the pump has been installed, make

certain that the pump and all piping or hose connections are tight, properly supported and secure before operation.



Do not operate the pump against a closed discharge valve. If operated against a closed discharge valve, pump components will deteriorate, and the liquid could come to a boil, build pressure, and cause the pump casing to rupture or explode. Momentary closure of a discharge valve is acceptable only when required for startup or shutdown procedures.



Do not remove plates, covers, gauges, pipe plugs, or fittings from an overheated pump. Vapor pressure within the pump can cause parts being disengaged to be ejected with great force. Allow the pump to cool completely before servicing.



This pump may be used to handle materials which could cause illness through direct exposure or emitted fumes. Wear adequate protective clothing when working on the pump or piping.



Do not operate the pump without guards in place over the rotating parts. Exposed rotating parts can catch clothing,

fingers or tools, causing severe injury to personnel.

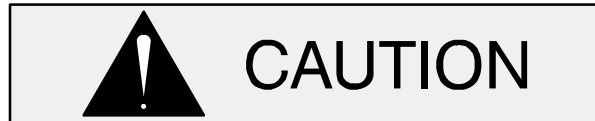

Make sure the pump is level. Lower jack stands and chock the wheels, if so equipped. Use caution when positioning the skid-mounted unit to prevent damage to the fuel tank.



Do not operate an internal combustion engine in an explosive atmosphere. When operating an internal combustion engine in an enclosed area, make sure exhaust fumes are piped to the outside. These fumes contain carbon monoxide, a deadly gas that is colorless, tasteless and odorless.



Fuel used by internal combustion engines presents an extreme explosion and fire hazard. Make certain that all fuel lines are securely connected and free of leaks. Never refuel a hot or running engine. Avoid overfilling the fuel tank. Always use the correct type of fuel.



Never tamper with the governor to gain more power. The governor establishes safe operating limits that should not be exceeded. Refer to the performance curve on page E-1 for the maximum continuous operating speed for this pump.

INSTALLATION – SECTION B

Review all SAFETY information in Section A.

Since pump installations are seldom identical, this section offers only general recommendations and practices required to inspect, position, and arrange the pump and piping.

Most of the information pertains to a standard **static lift application** where the pump is positioned above the free level of liquid to be pumped.

If installed in a **flooded suction application** where the liquid is supplied to the pump under pressure, some of the information such as mounting, line

configuration, and priming must be tailored to the specific application. Since the pressure supplied to the pump is critical to performance and safety, **be sure** to limit the incoming pressure to **50%** of the maximum permissible operating pressure as shown on the pump performance curve.

For further assistance, contact your Gorman-Rupp distributor or the Gorman-Rupp Company.

Pump Dimensions

See Figure 1 for the approximate physical dimensions of this pump.

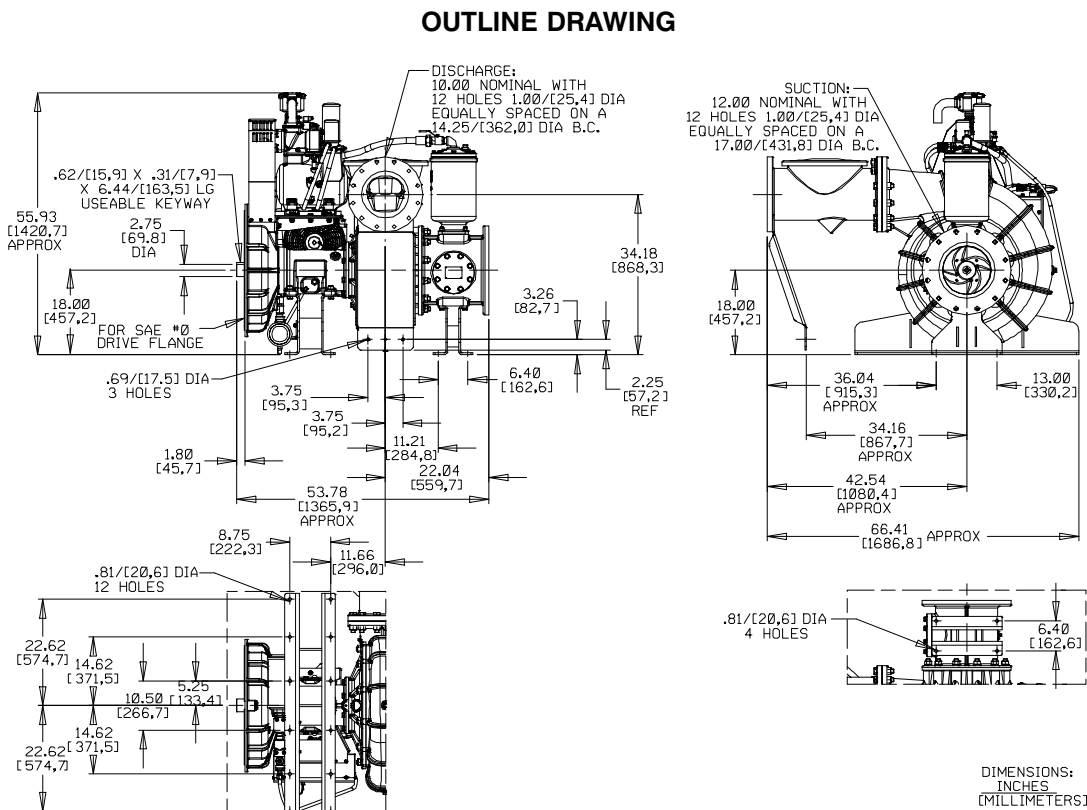

Figure 1. Pump Model PAH10A60C-B

PREINSTALLATION INSPECTION

The pump assembly was inspected and tested before shipment from the factory. Before installation, inspect the pump for damage which may have occurred during shipment. Check as follows:

- a. Inspect the pump for cracks, dents, damaged threads, and other obvious damage.
- b. Check for and tighten loose attaching hardware. Since gaskets tend to shrink after drying, check for loose hardware at mating surfaces.

- c. Carefully read all warnings and cautions contained in this manual or affixed to the pump, and perform all duties indicated. Note the direction of rotation indicated on the pump. Check that the pump shaft rotates counter-clockwise when facing the impeller.



Only operate this pump in the direction indicated by the arrow on the pump body and on the accompanying decal. Refer to **ROTATION** in **OPERATION**, Section C.

- d. Check levels and lubricate as necessary. Refer to **LUBRICATION** in the **MAINTENANCE AND REPAIR** section of this manual and perform duties as instructed.
- e. If the pump and power source have been stored for more than 12 months, some of the components or lubricants may have exceeded their maximum shelf life. These **must be inspected or replaced** to ensure maximum pump service.

If the maximum shelf life has been exceeded, or if anything appears to be abnormal, contact your Gorman-Rupp distributor or the factory to determine the repair or updating policy. **Do not** put the pump into service until appropriate action has been taken.

POSITIONING PUMP



Death or serious personal injury and damage to the pump or components can occur if proper lifting procedures are not observed. Make certain that hoists, chains, slings or cables are in good working condition and of sufficient capacity and that they are positioned so that loads will be balanced and the pump or components will not be damaged when lifting. Suction and discharge hoses and piping must be removed from the pump before lifting. Lift

the pump or component only as high as necessary and keep personnel away from suspended objects.

Lifting

Pump unit weights will vary depending on the mounting and drive provided. Check the shipping tag on the unit packaging for the actual weight, and use lifting equipment with appropriate capacity. Drain the pump and remove all customer-installed equipment such as suction and discharge hoses or piping before attempting to lift existing, installed units.

Mounting

Locate the pump in an accessible place as close as practical to the liquid being pumped. Level mounting is essential for proper operation.



If your pump is equipped with optional oil lubricated bearings, level mounting is essential to ensure sufficient lubrication to the pump bearings. Damage to the pump, including the bearings, shaft and/or bearing housing may occur if the pump is operated for an extended period of time on an unlevel surface. To ensure sufficient lubrication, never operate a unit equipped with oil lubricated bearings at an angle greater than 2° off level.

The pump may have to be supported or shimmed to provide for level operation or to eliminate vibration.

AIR COMPRESSOR ELECTRICAL CONNECTIONS

The air compressor provided with the pump requires a continuous 12VDC, 20 Amp power supply, to be supplied by the end user. Additionally, the air compressor is equipped with a 3A DC thermal shutdown switch which must be connected to the pump controller to shut down the pump if the air compressor reaches 240°F (115°C).

See Figure 6, Section E of this manual for the air compressor wiring schematic.

SUCTION AND DISCHARGE PIPING

Pump performance is adversely effected by increased suction lift, discharge elevation, and friction losses. See the performance curve and operating range shown on Page E-1 to be sure your overall application allows pump to operate within the safe operation range.

Materials

Either pipe or hose maybe used for suction and discharge lines; however, the materials must be compatible with the liquid being pumped. If hose is used in suction lines, it must be the rigid-wall, reinforced type to prevent collapse under suction. Using piping couplings in suction lines is not recommended.

Line Configuration

Keep suction and discharge lines as straight as possible to minimize friction losses. Make minimum use of elbows and fittings, which substantially increase friction loss. If elbows are necessary, use the long-radius type to minimize friction loss.

Connections to Pump

Before tightening a connecting flange, align it exactly with the pump port. Never pull a pipe line into place by tightening the flange bolts and/or couplings.

Lines near the pump must be independently supported to avoid strain on the pump which could cause excessive vibration, decreased bearing life, and increased shaft and seal wear. If hose-type lines are used, they should have adequate support to secure them when filled with liquid and under pressure.

Gauges

Most pumps are drilled and tapped for installing discharge pressure and vacuum suction gauges. If these gauges are desired for pumps that are not tapped, drill and tap the suction and discharge lines not less than 18 inches (457,2 mm) from the

suction and discharge ports and install the lines. Installation closer to the pump may result in erratic readings.

SUCTION LINES

To avoid air pockets which could affect pump priming, the suction line must be as short and direct as possible. When operation involves a suction lift, the line must always slope upward to the pump from the source of the liquid being pumped; if the line slopes down to the pump at any point along the suction run, air pockets will be created.

Fittings

Suction lines should be the same size as the pump inlet. If reducers are used in suction lines, they should be the eccentric type, and should be installed with the flat part of the reducers uppermost to avoid creating air pockets. Valves are not normally used in suction lines, but if a valve is used, install it with the stem horizontal to avoid air pockets.

Strainers

If a strainer is furnished with the pump, be certain to use it; any spherical solids which pass through a strainer furnished with the pump will also pass through the pump itself.

If a strainer is not furnished with the pump, but is installed by the pump user, make certain that the total area of the openings in the strainer is at least three or four times the cross section of the suction line, and that the openings will not permit passage of solids larger than the solids handling capability of the pump.

This pump is designed to handle up to 2-inch (50,8 mm) diameter spherical solids.

Sealing

Since even a slight leak will affect priming, head, and capacity, especially when operating with a high suction lift, all connections in the suction line should be sealed with pipe dope to ensure an air-tight seal. Follow the sealant manufacturer's recommendations when selecting and applying the pipe dope. The pipe dope should be compatible with the liquid being pumped.

Suction Lines In Sumps

If a single suction line is installed in a sump, it should be positioned away from the wall of the sump at a distance equal to 1 1/2 times the diameter of the suction line.

If there is a liquid flow from an open pipe into the sump, the flow should be kept away from the suction inlet because the inflow will carry air down into the sump, and air entering the suction line will reduce pump efficiency.

If it is necessary to position inflow close to the suction inlet, install a baffle between the inflow and the suction inlet at a distance 1 1/2 times the diameter of the suction pipe. The baffle will allow entrained air to escape from the liquid before it is drawn into the suction inlet.

If two suction lines are installed in a single sump, the flow paths may interact, reducing the efficiency

of one or both pumps. To avoid this, position the suction inlets so that they are separated by a distance equal to at least 3 times the diameter of the suction pipe.

Suction Line Positioning

The depth of submergence of the suction line is critical to efficient pump operation. Figure 2 shows recommended minimum submergence vs. velocity.

NOTE

The pipe submergence required may be reduced by installing a standard pipe increaser fitting at the end of the suction line. The larger opening size will reduce the inlet velocity. Calculate the required submergence using the following formula based on the increased opening size (area or diameter).

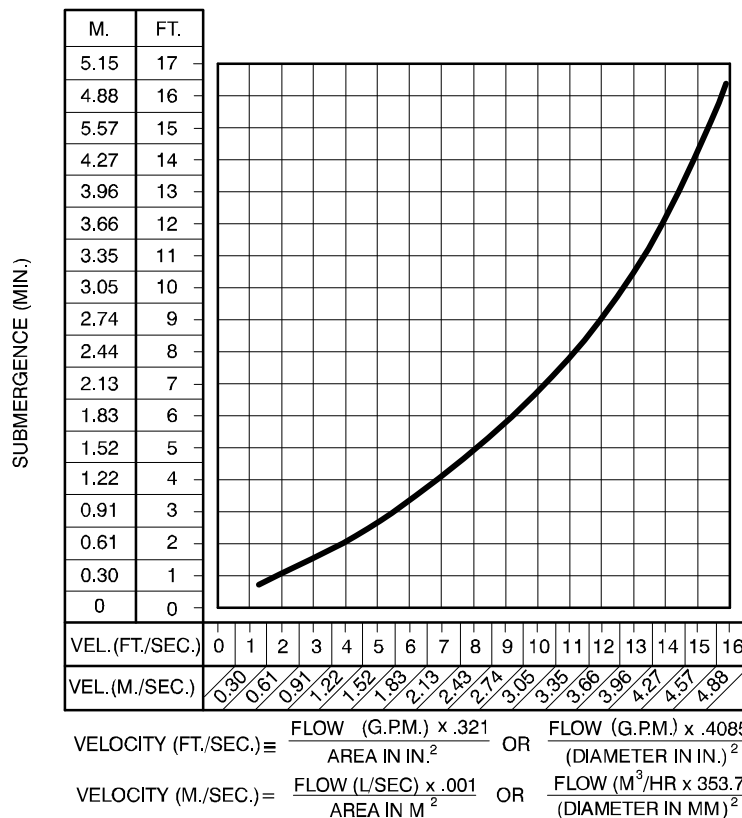

Figure 1. Recommended Minimum Suction Line Submergence vs. Velocity

DISCHARGE LINES

Siphoning

Do not terminate the discharge line at a level lower than that of the liquid being pumped unless a si-

phon breaker is used in the line. Otherwise, a siphoning action causing damage to the pump could result.

Valves

This pump is designed with a check valve in the discharge line.

If a throttling valve is desired in the discharge line, use a valve as large as the largest pipe to minimize friction losses. Never install a throttling valve in a suction line.

With high discharge heads, it is recommended that a throttling valve and a system check valve be installed in the discharge line to protect the pump from excessive shock pressure and reverse rotation when it is stopped.

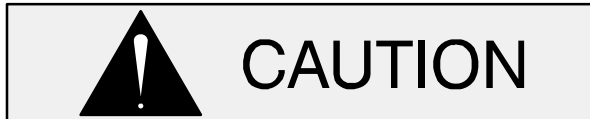

If the application involves a high discharge head, gradually close the discharge throttling valve before stopping the pump.

ALIGNMENT

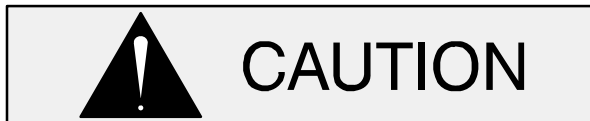

This pump is designed for direct coupled drive only. Use of a V-belt drive will damage the pump and void the pump warranty.

The alignment of the pump and its power source is critical for trouble-free mechanical operation. The driver and pump must be mounted so that their shafts are aligned with and parallel to each other. It is imperative that alignment be checked after the pump and piping are installed, and before operation.

NOTE

Check **Rotation**, Section C, before final alignment of the pump.

When mounted at the Gorman-Rupp factory, driver and pump are aligned before shipment. Misalign-

ment will occur in transit and handling. Pumps **must** be checked and realigned before operation. Before checking alignment, tighten the foundation bolts. The pump casing feet and/or pedestal feet, and the driver mounting bolts should also be tightly secured.



When checking alignment, disconnect the power source to ensure that the pump will remain inoperative.



Adjusting the alignment in one direction may alter the alignment in another direction. Check each procedure after altering alignment.

Coupled Drives

When using couplings, the axis of the power source must be aligned to the axis of the pump shaft in both the horizontal and vertical planes. Most couplings require a specific gap or clearance between the driving and the driven shafts. Refer to the coupling manufacturer's service literature.

Align spider insert type couplings by using calipers to measure the dimensions on the circumference of the outer ends of the coupling hub every 90°. The coupling is in alignment when the hub ends are the same distance apart at all points (see Figure 2).

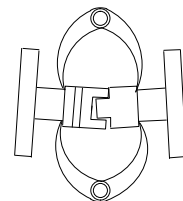

Figure 2. Aligning Spider-Type Couplings

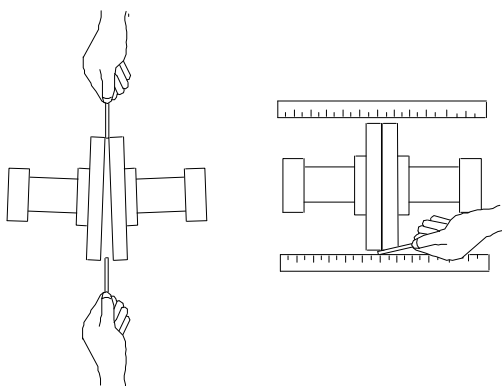

Figure 3. Aligning Non-Spider Type Couplings

Align non-spider type couplings by using a feeler gauge or taper gauge between the coupling halves every 90°. The coupling is in alignment when the hubs are the same distance apart at all points (see Figure 3).

Check parallel adjustment by laying a straightedge across both coupling rims at the top, bottom, and side. When the straightedge rests evenly on both halves of the coupling, the coupling is in horizontal parallel alignment. If the coupling is misaligned, use a feeler gauge between the coupling and the straightedge to measure the amount of misalignment.



Do not operate the pump without the guard in place over the rotating parts. exposed rotating parts can catch clothing, fingers, or tools, causing severe injury to personnel.

COLD WEATHER INSTALLATION

If the pump is to be installed in an environment where sub-freezing temperatures will occur during operation, consideration must be given to prevent the pump and components from freezing when the pump is idle between pumping cycles. With Gorman-Rupp priming assisted pumps, there are two methods of accomplishing this.

One method is through the use of an optional heated priming chamber, which is available as a factory-installed option or as a retrofit kit for most models (consult the factory). This method pumps heated liquid from the engine cooling system through the priming chamber to heat the chamber and its contents. This method is particularly effective where pumping cycles are short enough to ensure that the liquid in the priming chamber never fully freezes.

The second method involves configuring the pumping system to drain both the priming chamber and pump casing after each pumping cycle. With no liquid remaining in the system, freezing cannot occur.

To configure the pump to drain between pumping cycles, the first step is to remove the check valve from the line that runs between the top of the priming hopper and the priming venturi. This check valve is located close to the venturi end of the line. Remove the check valve, then reconnect the line directly to the venturi. This will allow air to enter the pump through the top of the priming hopper when the pump shuts off, providing for complete drainage of the pump and priming hopper.

Next, install a drain line between the pump drain and the wet well or sump. This line must remain submerged in the liquid below the pump down level of the liquid level control device; otherwise, the pump may not prime. If the application involves liquids that could clog the drain line, make sure to check the line periodically to ensure it remains open; otherwise, liquid could remain in the casing, resulting in freezing and potential damage to the pumping system.

Configuring the system to drain between cycles will help ensure that the pump will not freeze during cold weather applications. **However, it should be noted that the time required for the pump to begin to discharge liquid will increase, as the pump will have to fully re-prime at the beginning of each pumping cycle.**

OPERATION – SECTION C

Review all **SAFETY** information in Section A.

Follow the instructions on all tags, labels and decals attached to the pump.



This pump is designed to handle liquids containing large entrained solids and slurries. Do not attempt to pump volatile, corrosive, or flammable liquids which may damage the pump or endanger personnel as a result of pump failure.



Pump speed and operating condition points must be within the continuous performance range shown on the performance curve in Section E on page E-1.

PRIMING

Install the pump and piping as described in **INSTALLATION**. Make sure that the piping connections are tight, and that the pump is securely mounted. Check that the pump is properly lubricated (see **LUBRICATION** in **MAINTENANCE AND REPAIR**).

The pump will begin to prime upon startup. The air in the suction line will be discharged from the educator discharge line. Complete priming is indicated by a positive discharge pressure reading.

If full priming is not achieved, the discharge check valve may be malfunctioning. If this occurs, shut down the pump and consult **Maintenance and Repair**, Section E for further details.

STARTING

Consult the operations manual furnished with the power source.

Rotation

The correct direction of pump rotation is counter-clockwise when facing the impeller. The pump could be damaged and performance adversely affected by incorrect rotation. If pump performance is not within the specified limits (see the curve on page E-1), check the direction of power source rotation before further troubleshooting.

If an electric motor is used to drive the pump, remove the coupling or otherwise disconnect the pump from the motor before checking motor rotation. Operate the motor independently while observing the direction of the motor shaft or cooling fan.

If rotation is incorrect on a three-phase motor, have a qualified electrician interchange any two of the three phase wires to change direction.

Priming

The pump will begin to prime upon startup. The air in the suction line will be discharged from the educator discharge line. Complete priming is indicated by a positive discharge pressure reading.

If full priming is not achieved, the discharge check valve may be malfunctioning. If this occurs, shut down the pump and consult the separate **Maintenance and Repair** manual for further details.

OPERATION

Leakage

Once the pump is fully primed, no leakage should be visible at pump mating surfaces, or at pump connections or fittings. Keep all line connections and fittings tight to maintain maximum pump efficiency.

Liquid Temperature And Overheating

The **maximum** liquid temperature for this pump is 160°F (71°C). Do not apply it at a higher operating temperature.

Overheating can occur if operated with the valves in the suction or discharge lines closed. Operating against closed valves could bring the liquid to a boil, build pressure, and cause the pump to rupture or explode. If overheating occurs, stop the pump immediately and allow it to completely cool before servicing it. **Approach any over-heated pump cautiously.**



Allow an over-heated pump to completely cool before servicing. Do not remove plates, covers, gauges, or fittings from an overheated pump. Liquid within the pump can reach boiling temperatures, and vapor pressure within the pump can cause parts being disengaged to be ejected with great force. After the pump cools, drain the liquid from the pump by removing the casing drain plug. Use caution when removing the plug to prevent injury to personnel from hot liquid.

As a safeguard against rupture or explosion due to heat, this pump is equipped with a pressure relief valve which will open if vapor pressure within the pump casing reaches a critical point. If overheating does occur, stop the pump immediately and allow it to cool before servicing it. **Approach any over-heated pump cautiously.** It is recommended that the pressure relief valve assembly be replaced at each overhaul, or any time the pump casing over-heats and activates the valve. **Never** replace this valve with a substitute which has not been specified or provided by the Gorman-Rupp Company.

Strainer Check

If a suction strainer has been shipped with the pump or installed by the user, check the strainer regularly, and clean it as necessary. The strainer

should also be checked if pump flow rate begins to drop. Monitor and record the vacuum suction gauge readings regularly to detect strainer blockage.

Never introduce air or steam pressure into the pump casing or piping to remove a blockage. This could result in personal injury or damage to the equipment. If backflushing is absolutely necessary, **liquid pressure** must be limited to 50% of the maximum permissible operating pressure shown on the pump performance curve.

Pump Vacuum Check

With the pump inoperative, install a vacuum gauge in the system, using pipe dope on the threads. Block the suction line and start the pump. At operating speed the pump should pull a vacuum of 20 inches (508,0 mm) or more of mercury. If it does not, check for air leaks in the seal, gasket, or discharge valve.

Open the suction line, and read the vacuum gauge with the pump primed and at operation speed. Shut off the pump. The vacuum gauge reading will immediately drop proportionate to static suction lift, and should then stabilize. If the vacuum reading falls off rapidly after stabilization, an air leak exists. Before checking for the source of the leak, check the point of installation of the vacuum gauge.

STOPPING

Never halt the flow of liquid suddenly. If the liquid being pumped is stopped abruptly, damaging shock waves can be transmitted to the pump and piping system. Close all connecting valves slowly.



Do not operate the pump against a closed discharge throttling valve for long periods of time. If operated against a closed discharge throttling valve, pump components will deteriorate, and the liquid could come to a boil, build pressure, and cause the pump casing to rupture or explode.

PERIODIC CHECKS

Seal Cavity And Bearing Lubrication

Both the seal and bearing cavities were fully lubricated at the factory. Check the lubrication levels before startup, and regularly thereafter as indicated in Section E, **Maintenance and Repair**. When lubrication is required, use **only** SAE No. 30 non-detergent oil.

Bearing Temperature Check

Bearings normally run at higher than ambient temperatures because of heat generated by friction. Temperatures up to 160°F (71°C) are considered normal for bearings, and they can operate safely to at least 180°F (82°C).

Checking bearing temperatures by hand is inaccurate. Bearing temperatures can be measured accurately by placing a contact-type thermometer against the housing. Record this temperature for future reference.

A sudden increase in bearing temperatures is a warning that the bearings are at the point of failing to operate properly. Make certain that the bearing lubricant is of the proper viscosity and at the correct level (see **LUBRICATION** in Section E, **Maintenance and Repair**). Bearing overheating can also be caused by shaft misalignment and/or excessive vibration.

When pumps are first started, the bearings may seem to run at temperatures above normal. Continued operation should bring the temperatures down to normal levels.

Air Compressor

The air compressor was lubricated for test at the factory. However, **always** check the lubrication level before startup.

Consult the manual accompanying the air compressor and preform all duties and checks as indicated.

COLD WEATHER PRESERVATION

If the pump will be idle for an extended period of time in below freezing conditions, drain the pump and priming hopper to prevent damage from freezing. Also, clean out any solids by flushing with a hose. Operate the pump for approximately one minute; this will remove any remaining liquid that could freeze the pump rotating parts. If the pump will be idle for more than a few hours, or if it has been pumping liquids containing a large amount of solids, drain the pump, and flush it thoroughly with clean water. To prevent large solids from clogging the drain port and preventing the pump from completely draining, insert a rod or stiff wire in the drain port, and agitate the liquid during the draining process. Clean out any remaining solids by flushing with a hose.

If the pump is to be installed in an environment where sub-freezing temperatures will occur during operation, consideration must be given to prevent the pump and components from freezing when the pump is idle between pumping cycles. Refer to **COLD WEATHER INSTALLATION** in the **Installation** section of this manual for details.

TROUBLESHOOTING – SECTION D

Review all SAFETY information in Section A.



Before attempting to open or service the pump:

1. Familiarize yourself with this manual.
2. Lock out or disconnect the power source to ensure that the pump will remain inoperative.
3. Allow the pump to completely cool if overheated.
4. Check the temperature and make sure pump is cool before opening any covers, plates, or plugs.
5. Close the suction and discharge valves.
6. Vent the pump slowly and cautiously.
7. Drain the pump.

TROUBLE	POSSIBLE CAUSE	PROBABLE REMEDY
PUMP FAILS TO PRIME	Discharge check valve contaminated, damaged, or unable to seat. Air leak in suction line. Lining of suction hose collapsed. Leaking or worn seal or pump gasket. Suction lift or discharge head too high. Air compressor damaged or belts broken. Strainer clogged.	Clean or replace check valve. Correct leak. Replace suction hose. Check pump vacuum. Replace leaking or worn seal or gasket. Check piping installation and install bypass line if needed. See INSTALLATION . Check and repair/replace. Check strainer and clean if necessary.
PUMP STOPS OR FAILS TO DELIVER RATED FLOW OR PRESSURE	Eductor clogged. Air leak in suction line. Lining of suction hose collapsed. Leaking or worn seal or pump gasket.	Check and clean eductor. Correct leak. Replace suction hose. Check pump vacuum. Replace leaking or worn seal or gasket.

TROUBLE	POSSIBLE CAUSE	PROBABLE REMEDY
PUMP STOPS OR FAILS TO DELIVER RATED FLOW OR PRESSURE (cont.)	<p>Strainer clogged.</p> <p>Discharge check valve clogged.</p> <p>Suction intake not submerged at proper level or sump too small.</p> <p>Impeller or other wearing parts worn or damaged.</p> <p>Impeller clogged.</p> <p>Suction lift too high.</p> <p>Pump speed too slow.</p> <p>Belt or flexible coupling broken.</p>	<p>Check strainer and clean if necessary.</p> <p>Check and clean check valve.</p> <p>Check installation and correct submergence as needed.</p> <p>Replace worn or damaged parts. Check that impeller is properly centered and rotates freely.</p> <p>Free impeller of debris.</p> <p>Measure lift w/vacuum gauge. Reduce lift and/or friction losses in suction line.</p> <p>Check driver output; consult driver operation manual.</p> <p>Check and replace as necessary.</p>
PUMP REQUIRES TOO MUCH POWER	<p>Pump speed too high.</p> <p>Extreme ambient temperature.</p> <p>Discharge head too low.</p> <p>Fuel filter clogged.</p> <p>Liquid solution too thick.</p> <p>Fuel contaminated.</p> <p>Pump or jack shaft bearing(s) frozen.</p>	<p>Check driver output.</p> <p>Reduce pump output.</p> <p>Adjust discharge valve.</p> <p>Check & replace often in extreme operating conditions.</p> <p>Dilute if possible.</p> <p>Check and replace as required.</p> <p>Disassemble, check and replace bearing(s) as required..</p>
PUMP CLOGS FREQUENTLY	<p>Discharge flow too slow.</p> <p>Suction check valve or foot valve clogged or binding.</p> <p>Liquid solution too thick.</p>	<p>Open discharge valve fully to increase flow rate, and run engine at maximum governed speed.</p> <p>Clean valve.</p> <p>Dilute if possible.</p>
EXCESSIVE NOISE	<p>Cavitation in pump.</p> <p>Pumping entrained air.</p> <p>Pump or drive not securely mounted.</p> <p>Impeller clogged or damaged.</p>	<p>Reduce suction lift and/or friction losses in suction line. Record vacuum and pressure gauge readings and consult local representative or factory.</p> <p>Locate and eliminate source of air bubble.</p> <p>Secure mounting hardware.</p> <p>Clean out debris; replace damaged parts.</p>

TROUBLE	POSSIBLE CAUSE	PROBABLE REMEDY
BEARINGS RUN TOO HOT	<p>Bearing temperature is high, but within limits.</p> <p>Low or incorrect lubricant.</p> <p>Suction and discharge lines not properly supported.</p> <p>Drive misaligned.</p> <p>Excessive tension on drive belt.</p>	<p>Check bearing temperature regularly to monitor any increase.</p> <p>Check for proper type and level of lubricant.</p> <p>Check piping installation for proper support.</p> <p>Align drive properly.</p> <p>Check belt tension. Adjust as required.</p>

PREVENTIVE MAINTENANCE

Since pump applications are seldom identical, and pump wear is directly affected by such things as the abrasive qualities, pressure and temperature of the liquid being pumped, this section is intended only to provide general recommendations and practices for preventive maintenance. Regardless of the application however, following a routine preventive maintenance schedule will help assure trouble-free performance and long life from your Gorman-Rupp pump. For specific questions concerning your application, contact your Gorman-Rupp distributor or the Gorman-Rupp Company.

Record keeping is an essential component of a good preventive maintenance program. Changes in suction and discharge gauge readings (if so

equipped) between regularly scheduled inspections can indicate problems that can be corrected before system damage or catastrophic failure occurs. The appearance of wearing parts should also be documented at each inspection for comparison as well. Also, if records indicate that a certain part (such as the seal) fails at approximately the same duty cycle, the part can be checked and replaced before failure occurs, reducing unscheduled down time.

For new applications, a first inspection of wearing parts at 250 hours will give insight into the wear rate for your particular application. Subsequent inspections should be performed at the intervals shown on the chart below. Critical applications should be inspected more frequently.

Preventive Maintenance Schedule					
Item	Service Interval*				
	Daily	Weekly	Monthly	Semi-Annually	Annually
General Condition (Temperature, Unusual Noises or Vibrations, Cracks, Leaks, Loose Hardware, Etc.)	I				
Pump Performance (Gauges, Speed, Flow)	I				
Bearing Lubrication				I	
Seal Lubrication (And Packing Adjustment, If So Equipped)		I		R	
V-Belts (If So Equipped)			I		
Air Release Valve Plunger Rod (If So Equipped)			I	C	
Front Impeller Clearance (Wear Plate)				I	
Rear Impeller Clearance (Back Plate)				I	
Check Valve					I
Pressure Relief Valve (If So Equipped)					C
Pump and Driver Alignment					I
Shaft Deflection					I
Bearings				I	
Bearing Housing				I	
Piping					I
Driver Lubrication – See Mfgr’s Literature					

Legend:
 I = Inspect, Clean, Adjust, Repair or Replace as Necessary
 C = Clean
 R = Replace

* Service interval based on an intermittent duty cycle equal to approximately 4000 hours annually. Adjust schedule as required for lower or higher duty cycles or extreme operating conditions.

PUMP MAINTENANCE AND REPAIR – SECTION E

MAINTENANCE AND REPAIR OF THE WEARING PARTS OF THE PUMP WILL MAINTAIN PEAK OPERATING PERFORMANCE.

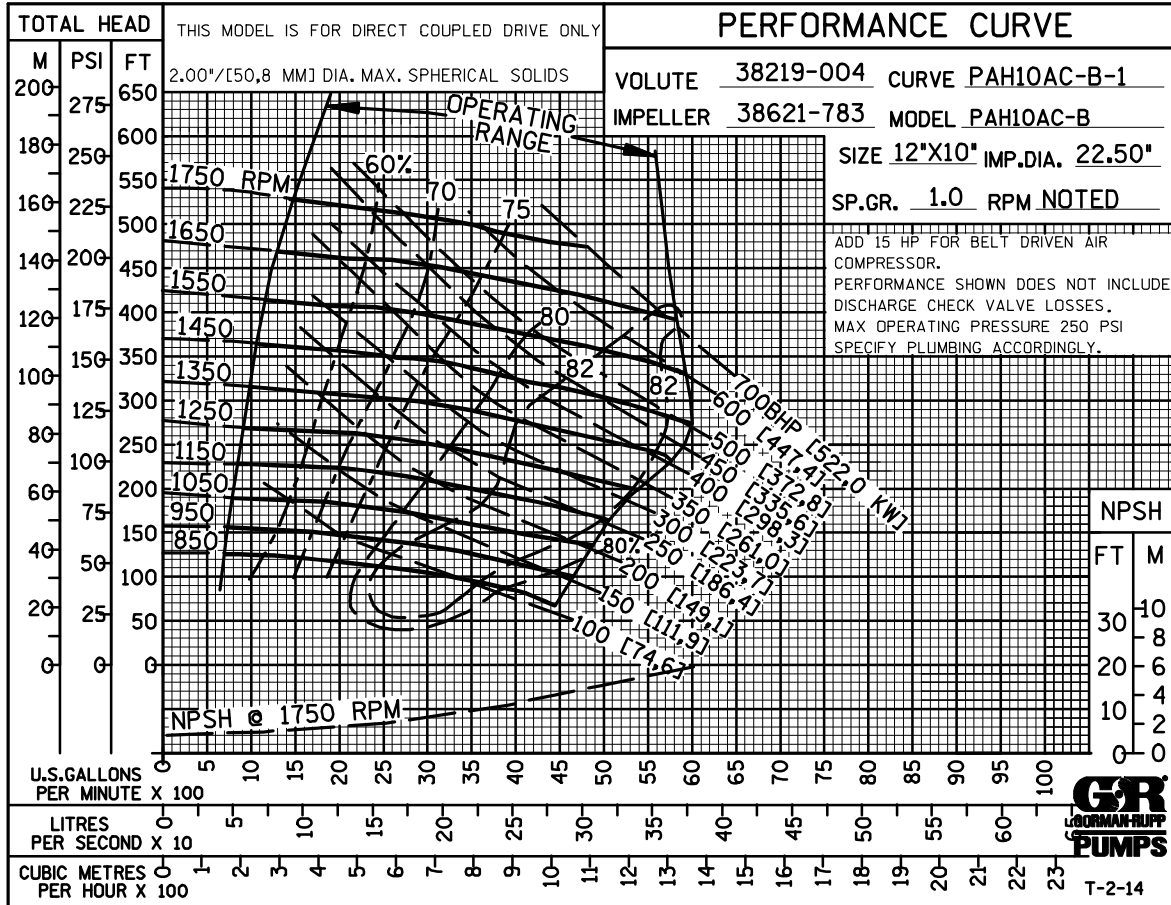

*** STANDARD PERFORMANCE FOR PUMP MODEL PAH10A60C-B**

* Based on 70°F (21°C) clear water at sea level with minimum suction lift. Since pump installations are seldom identical, your performance may be different due to such factors as viscosity, specific gravity, elevation, temperature, and impeller trim.

Contact the Gorman-Rupp Company to verify performance or part numbers.

If your pump serial number is followed by an "N", your pump is **NOT** a standard production model.

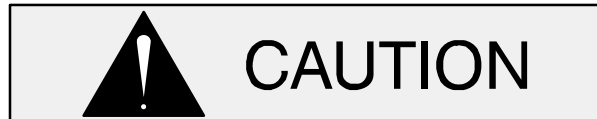

Pump speed and operating condition points must be within the continuous performance range shown on the curve.

ILLUSTRATION

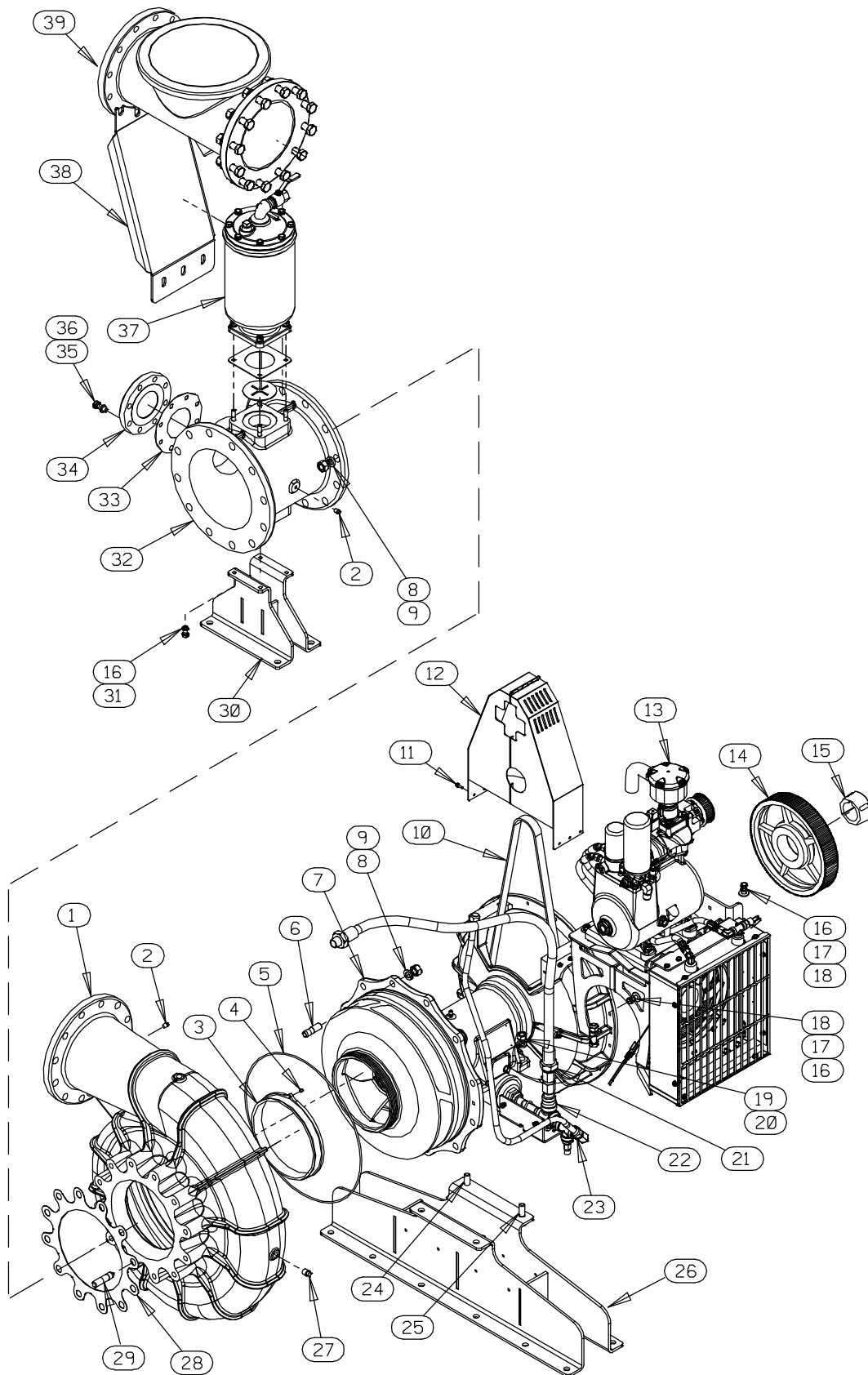

Figure 1. Pump Model PAH10A60C-B

PARTS LIST
Pump Model PAH10A60C-B
 (From S/N 1615058 Up)

ITEM NO.	PART NAME	PART NUMBER	QTY	ITEM NO.	PART NAME	PART NUMBER	QTY
1	PUMP CASING	SEE NOTE BELOW	1	29	STUD	C1414 15991	12
2	PIPE PLUG	P04 15079	2	30	SUCT SUPPORT ASSY	41888-301 24150	1
3	WEAR RING	38691-639 11010	1	31	HEX HEAD CAP SCREW	B0805 15991	4
4	A HD SET SCREW	GA0601-1/2 17090	2	32	12" SPOOL FLANGE	38642-622 10000	1
5	O-RING	25152-391	1	33 *	GASKET	25113-034	1
6	STUD	C1412 15991	12	34	4" BLIND FLANGE ASSY	42111-358	1
7	REPAIR ROTATING ASSY	44163-670	1		-WARNING PLATE	2613EV 13990	1
8	LOCK WASHER	J14 15991	24		-DRIVE SCREW	BM#04-03 17000	4
9	HEX NUT	D14 15991	24	35	HEX HEAD CAP SCREW	B1007 15991	8
10 *	BELT	24186-016	1	36	LOCK WASHER	J10 15991	8
11	FLANGED CAPSCREW	21634-505	6	37	PRIMING CHAMBER KIT	48275-006	1
12	BELT GUARD ASSEMBLY	42351-523	1	38	SUPPORT BRACKET	34778-030 15080	1
13	AIR COMPRESSOR ASSY	46181-913	1	39	CHECK VALVE KIT 10"	48274-007	1
14	SPROCKET	24271-124	1		-CHECK VALVE	26642-127	1
15	BUSHING	24131-435	1	*	-FLAPPER	26688-007	1
16	LOCK WASHER	J08 15991	10	*	-COVER GASKET	26688-008	1
17	FLAT WASHER	K08 15991	6	*	-FLANGE GASKET	25113-040	1
18	HEX HEAD CAP SCREW	B0806 15991	6	NOT SHOWN:			
19	HEX NUT	D12 15991	2		G-R DECAL 6 IN	GR-06	1
20	LOCK WASHER	J12 15991	2		PRIME AIRE PLUS DECAL	38812-099	1
21	VACUUM HOSE ASSY	46341-021	1		NAMEPLATE BLANK	38819-002 13000	1
22	VENTURI ASSEMBLY	48227-403	1		DRIVE SCREW	BM#04-03 17000	4
23	HOSE ASSEMBLY	46341-035	1		DISCHARGE STICKER	6588BJ	1
24	HEX HEAD CAP SCREW	B1210 15991	1		SUCTION STICKER	6588AG	1
25	HEX HEAD CAP SCREW	B1211 15991	1		WARNING DECAL	2613FE	1
26	SUPPORT ASSEMBLY	41888-300 24150	1		ROTATION DECAL	2613M	1
27	PIPE PLUG	P08 15079	3		INSTRUCTION TAG	38817-085	1
28 *	GASKET	38685-808 18000	1				

* INDICATES PARTS RECOMMENDED FOR STOCK

☞ INCLUDED WITH REPAIR 46474-357 1
 PUMP CASING ASSY

ILLUSTRATION

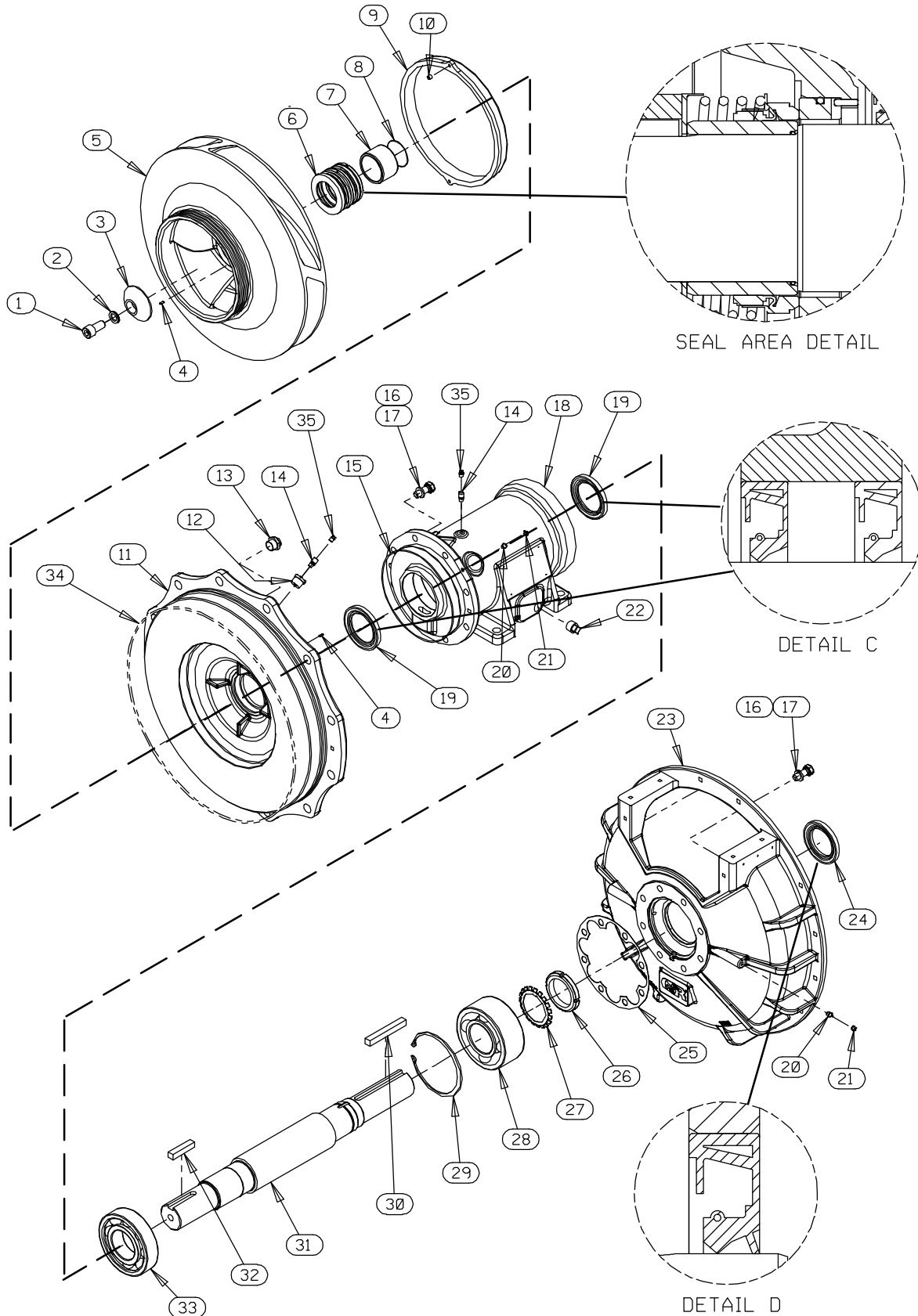

Figure 2. Repair Rotating Assembly

PARTS LIST
Repair Rotating Assembly

ITEM NO.	PART NAME	PART NUMBER	QTY
1	SOCKET HEAD CAP SCREW	DM1206 15991	1
2	WASHER NORD-LOCK 3/4"	21177-224	1
3	IMPELLER WASHER	31167-041 17000	1
4	ROLL PIN	S2197	2
5	* IMPELLER	38621-783 11010	1
6	* 3.25" MECH SEAL	25285-823	1
7	* SHAFT SLEEVE	31163-023 17000	1
8	* O-RING	25154-036	1
9	* WEAR RING	38691-638 11010	1
10	A HD SET SCREW	GA0601-1/2 17090	2
11	SEAL PLATE	38272-615 11010	1
12	REDUCER PIPE BUSHING	AP1202 15079	1
13	SIGHT GAUGE	S1471	2
14	AIR VENT	S1530	2
15	* O-RING	25152-177	1
16	HEX HEAD CAP SCREW	B1007 15991	16
17	LOCK WASHER	J10 15991	16
18	PEDESTAL	38257-316 10000	1
19	OIL SEAL	25227-920	2
20	LUBE FITTING	S186	4
21	CAP PLUG	25141-151	4
22	PIPE PLUG	P12 15079	3
23	DRIVE FLANGE - SAE 0	38545-026 10000	1
24	* OIL SEAL	25227-862	1
25	* GASKET	38683-668 19060	1
26	BEARING LOCKNUT	23962-017	1
27	BEARING LOCKWASHER	23962-517	1
28	* BALL BEARING	23421-417	1
29	RETAINING RING	24121-088	1
30	* DRIVE KEY	N1020 15990	1
31	IMPELLER SHAFT	38512-540 1600X	1
32	* IMPELLER KEY	N1012 15990	1
33	* BALL BEARING	23275-017	1
34	* O-RING	25152-391	1
35	SHIPPING PLUG	11495C 15079	2
NOT SHOWN:			
	INSTRUCTION TAG	6588U	1

* INDICATES PARTS RECOMMENDED FOR STOCK

ILLUSTRATION

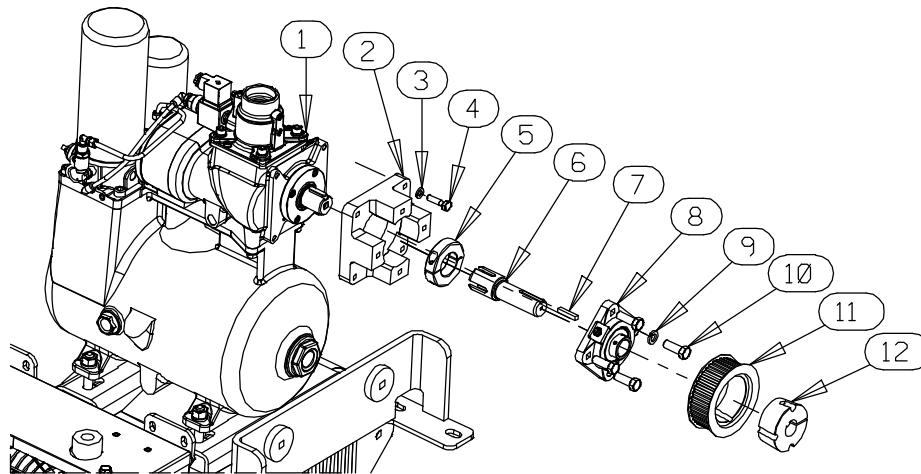
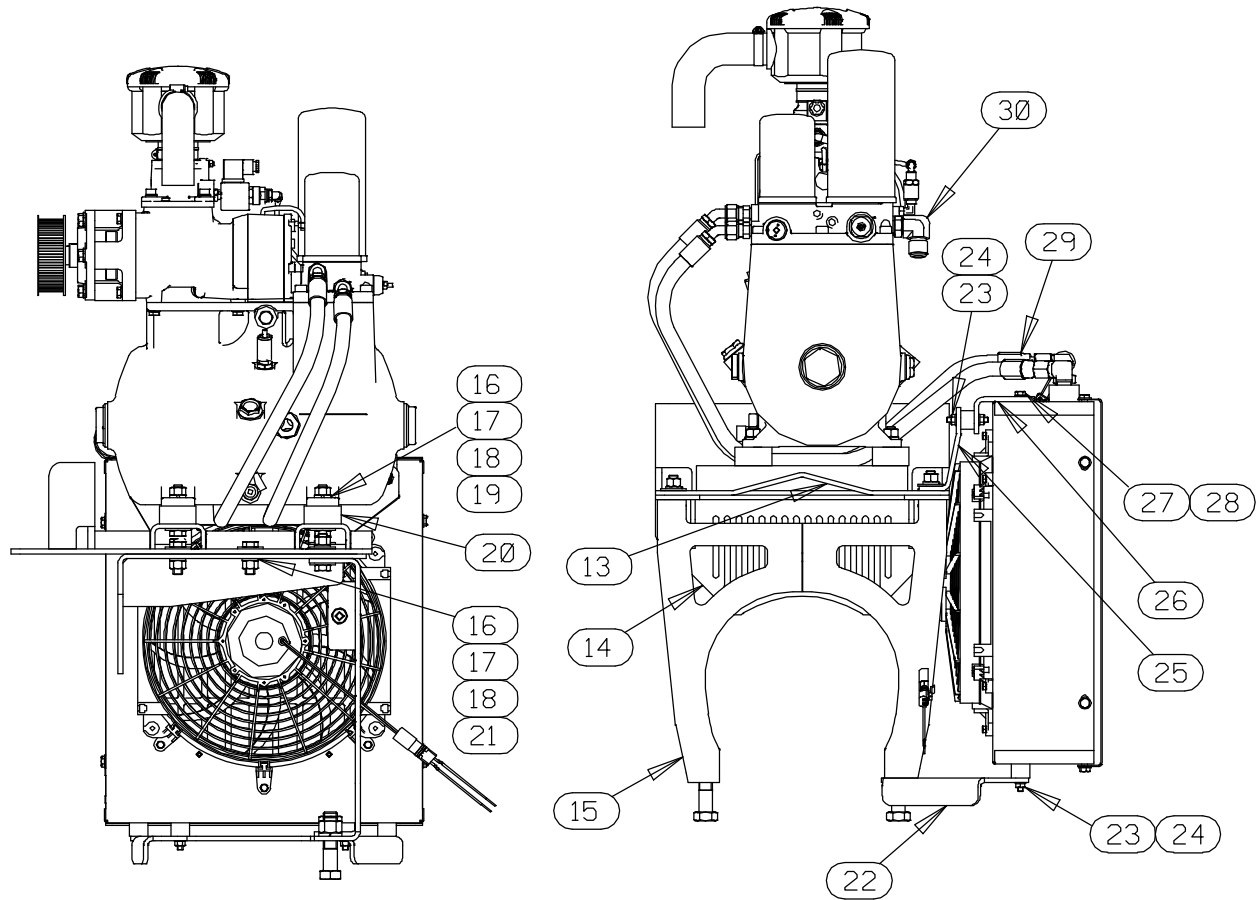

SEE FIGURE 6 FOR AIR COMPRESSOR WIRING SCHEMATIC

Figure 3. Air Compressor Assembly

PARTS LIST
Air Compressor Assembly

ITEM NO.	PART NAME	PART NUMBER	QTY
1	VANAIR 60 CFM COMPRESSOR	26813-114	1
2	MOUNTING BRACKET	38138-090 13000	1
3	LOCK WASHER	21171-510	4
4	HEX HEAD CAP SCREW	22645-135	4
5	SHAFT COLLAR	24118-035	1
6	ADAPTER SHAFT	38513-420 16040	1
7	KEY	N0405 15990	1
8	FLANGE BEARING	23918-101	1
9	LOCK WASHER	J07 15991	4
10	HEX HEAD CAP SCREW	B0705 15991	4
11	SPROCKET	24271-123	1
12	BUSHING	24131-881	1
13	BRACKET ASSEMBLY	41888-312 24150	1
14	BRACKET ASSEMBLY	41888-313 24150	1
15	SUPPORT BRACKET ASSEMBLY	41888-414	1
16	LOCK WASHER	J08 15991	8
17	FLAT WASHER	K08 15991	7
18	HEX NUT	D08 15991	8
19	HEX HEAD CAP SCREW	B0810 15991	4
20	SPACER	31131-104 15000	4
21	HEX HEAD CAP SCREW	B0806 15991	4
22	MOUNTING BRACKET	34455-022 15080	1
23	HEX NUT W/FLG	21765-312	12
24	RUBBER ISOLATOR MOUNT	24631-015	8
25	MOUNTING BRACKET	34335-197 15080	1
26	MOUNTING BRACKET	34225-086 15080	1
27	HEX HEAD CAP SCREW	B0503-1/2 15991	4
28	LOCK WASHER	J05 15991	4
29	HOSE ASSEMBLY	46341-034	2
30	90° ELBOW	26523-151	1

ILLUSTRATION

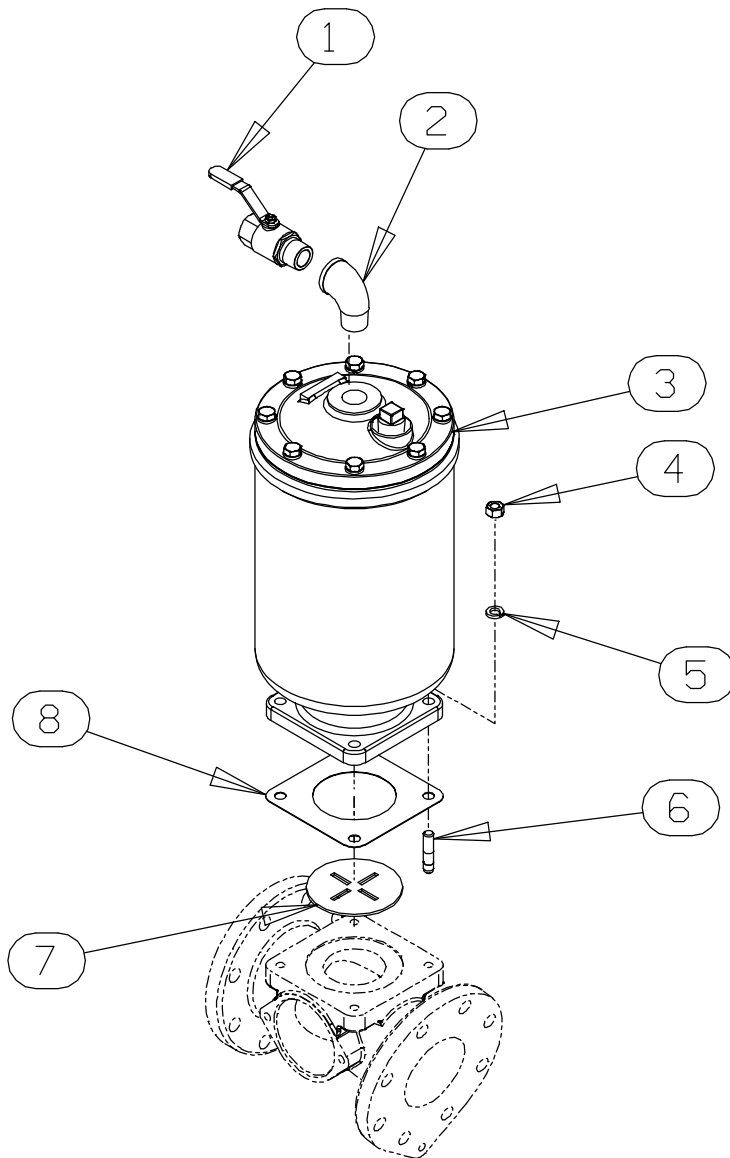

Figure 4. Priming Chamber Kit

PARTS LIST

ITEM NO.	PART NAME	PART NUMBER	QTY
1	BALL VALVE	26631-054	1
2	STREET ELBOW	RS16 11999	1
3	PRIMING CHAMBER ASSEMBLY	46112-709	1
4	HEX NUT	D08 15991	4
5	LOCK WASHER	J08 15991	4
6	STUD	C0809 15991	4
7	BAFFLE	31113-011 17000	1
8	* GASKET	38687-053 19060	1

* INDICATES PARTS RECOMMENDED FOR STOCK

ILLUSTRATION

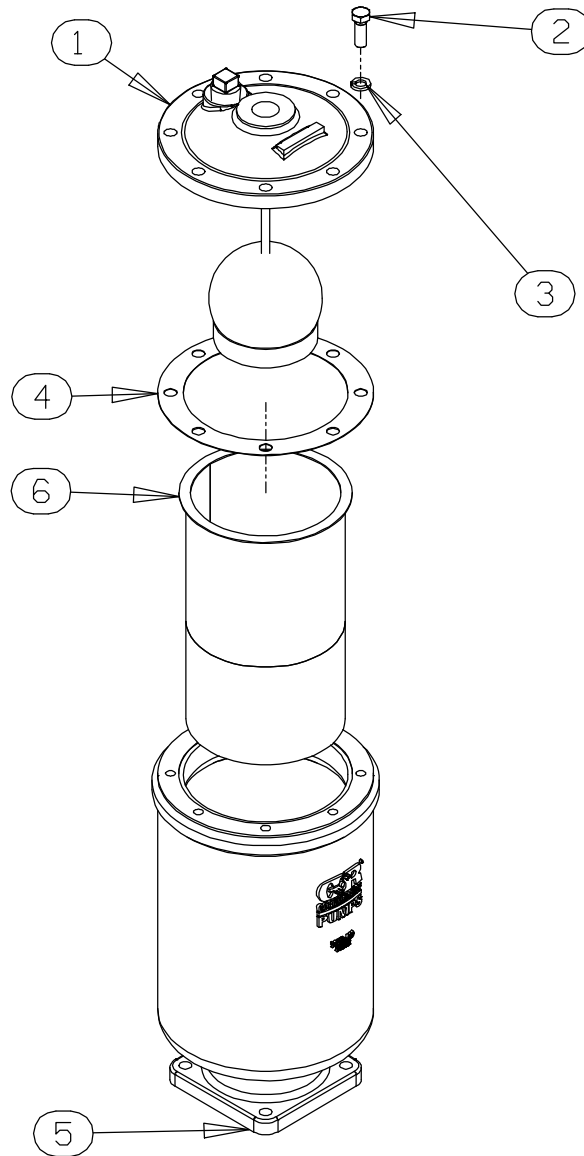

Figure 5. Priming Chamber Assembly

PARTS LIST

ITEM NO.	PART NAME	PART NUMBER	QTY
1	PRIMING VALVE	26664-007	1
	-ORIFICE BUTTON	26688-021	1
2	HEX HD CAPSCREW	B0806 15991	8
3	LOCKWASHER	J08 15991	8
4	* PRIMING VALVE GASKET	38683-657 19060	1
5	PRIMING CHAMBER	38343-020 10000	1
6	STRAINER ASSY	46641-222 17000	1

* INDICATES PARTS RECOMMENDED FOR STOCK

ILLUSTRATION

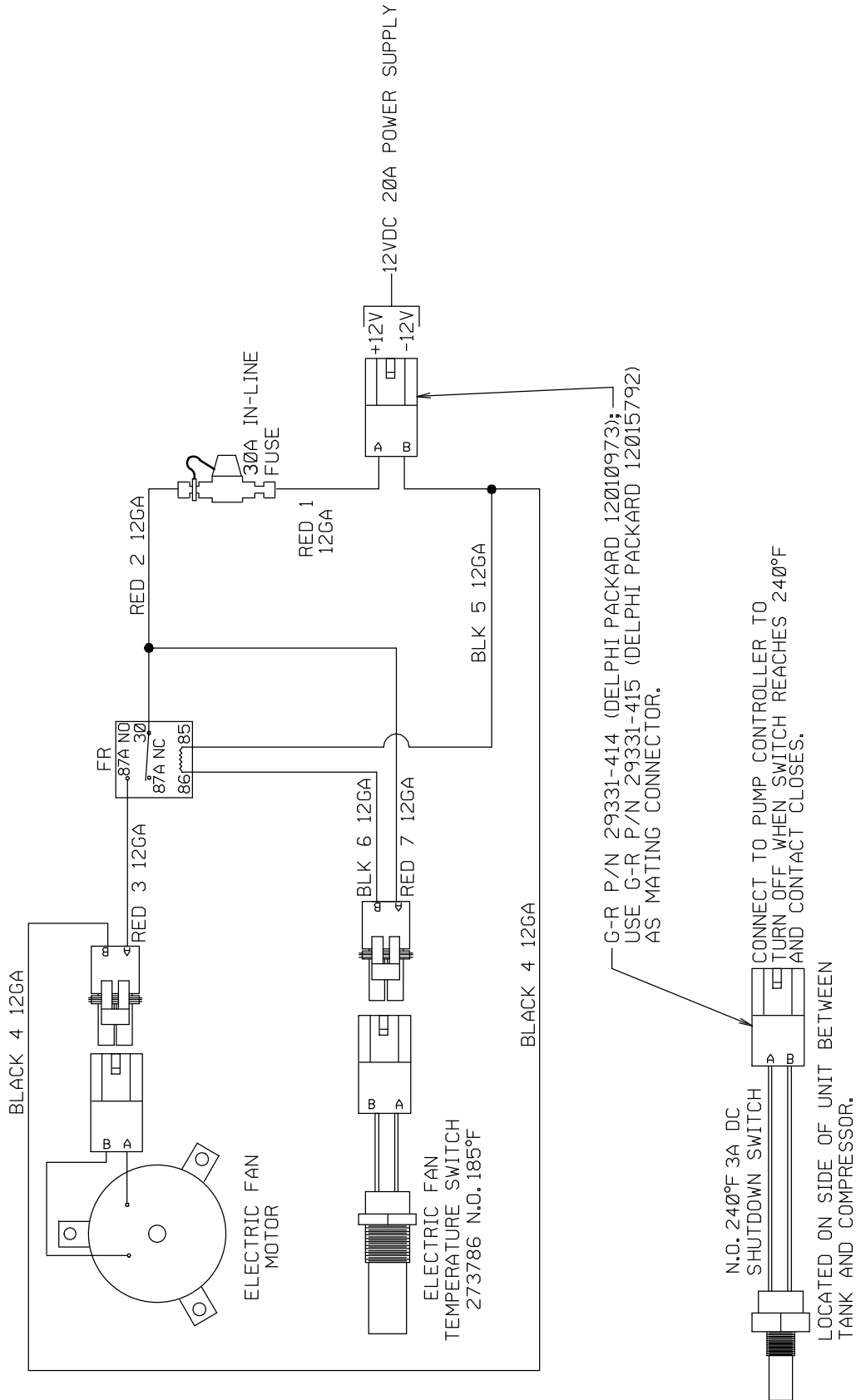

Figure 6. Air Compressor Wiring Schematic

ILLUSTRATION

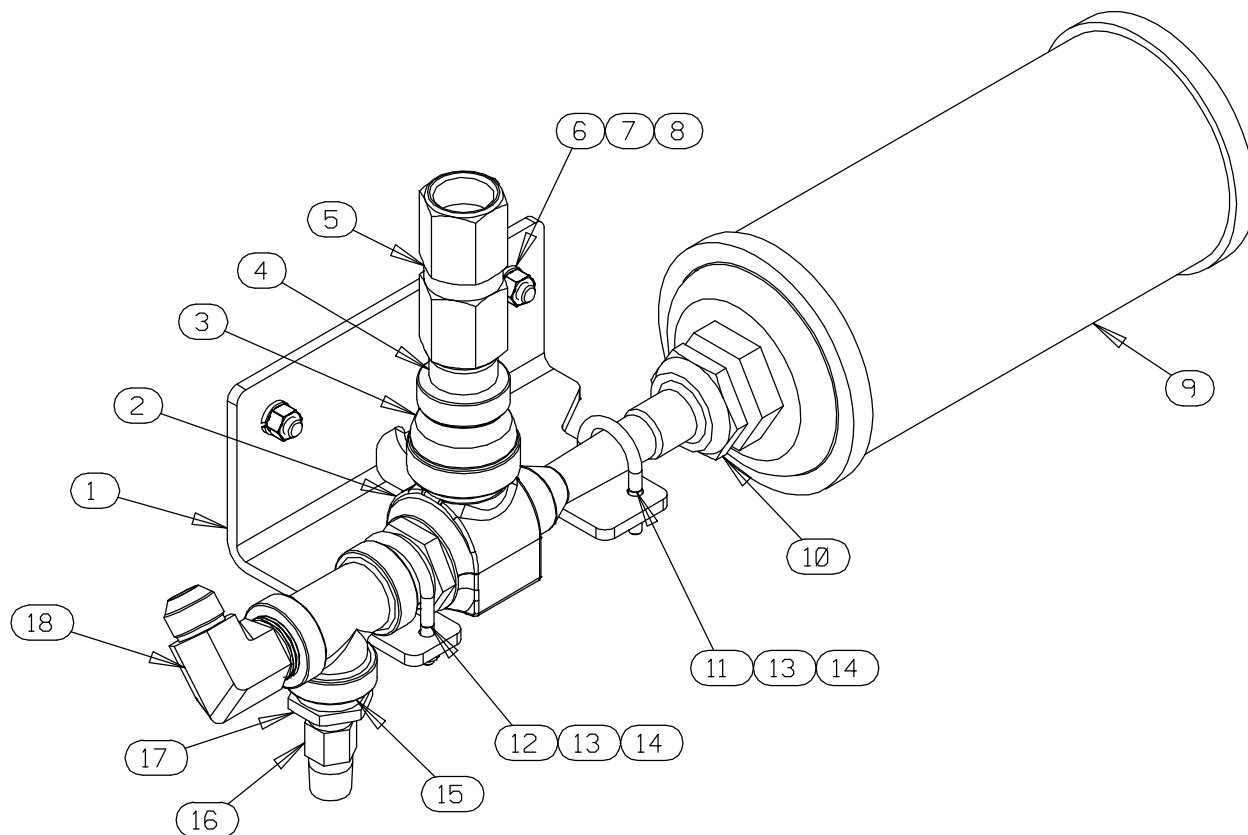

Figure 7. Venturi Assembly
PARTS LIST

ITEM NO.	PART NAME	PART NUMBER	QTY
1	BRACKET	34266-075 15080	1
2	* VENTURI	26817-007	1
3	REDUCER PIPE COUPLING	AE2016 15079	1
4	PIPE NIPPLE	T1608 15079	1
5	* CHECK VALVE	26641-093	1
6	LOCK WASHER	J06 15991	2
7	HEX NUT	D06 15991	2
8	HEX HEAD CAP SCREW	B0605 15991	2
9	* MUFFLER	29334-092	1
10	REDUCER PIPE BUSHING	AP2420 11999	1
11	U BOLT	21751-028	1
12	U BOLT	21751-019	1
13	LOCK WASHER	J04 15991	4
14	HEX NUT	D04 15991	4
15	PIPE TEE	U16 11999	1
16	* PRESSURE RELIEF VALVE	26662-028	1
17	REDUCER PIPE BUSHING	AP1608 11999	1
18	90° ELBOW ADAPTER	26523-141	1

* INDICATES PARTS RECOMMENDED FOR STOCK

PUMP AND SEAL DISASSEMBLY AND REASSEMBLY

Review all **SAFETY** information in Section A.

Follow the instructions on all tags, label and decals attached to the pump.

This pump requires little service due to its rugged, minimum-maintenance design. However, if it becomes necessary to inspect or replace the wearing parts, follow these instructions which are keyed to the illustrations (see Figures 1 through 7) and the corresponding parts lists. Instructions for the air compressor are covered separately in specific literature available from the manufacturer.

Some pump service functions may be performed without separating the pump end assembly from the power source. However, the priming chamber (37, Figure 1) and discharge check valve assembly (39, Figure 1) must be removed to service most pump components. The following instructions assume complete disassembly of the pump is required.

Before attempting to service the pump, lock out or disconnect the power source and take precautions to ensure that it will remain inoperative. Close all valves in the suction and discharge lines and drain the pump casing by removing the lowermost pipe plug (27, Figure 1). Clean and reinstall the pipe plug.



This manual will alert personnel to known procedures which require special attention, to those which could damage equipment, and to those which could be dangerous to personnel. However, this manual cannot possibly anticipate and provide detailed instructions and precautions for every situation that might occur during maintenance of the unit. Therefore, it is the responsibility of the owner/maintenance personnel to

ensure that only safe, established maintenance procedures are used, and that any procedures not addressed in this manual are performed only after establishing that neither personal safety nor pump integrity are compromised by such practices.



Before attempting to open or service the pump:

1. Familiarize yourself with this manual.
2. Lock out or disconnect the power source to ensure that the pump will remain inoperative.
3. Allow the pump to completely cool if overheated.
4. Check the temperature and make sure it is cool before opening any covers, plates, gauges, or plugs.
5. Close the suction and discharge valves.
6. Vent the pump slowly and cautiously.
7. Drain the pump.



Death or serious personal injury and damage to the pump or components can occur if proper lifting procedures are not observed. Make certain that hoists, chains, slings or cables are in good working condition and of sufficient capacity and that they are positioned so that loads will be balanced and the pump or components will not be damaged when lifting. Suction and discharge hoses and piping must be removed from the pump before lifting. Lift the pump or component only as high as

necessary and keep personnel away from suspended objects.

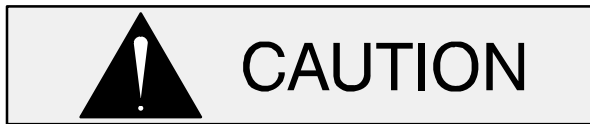

Use **only** replacement parts provided or approved by Gorman-Rupp. Use of non-authorized parts may result in damage to the equipment and/or injury to personnel and **will** invalidate the warranty.

Priming Chamber Removal And Disassembly

(Figure 4)

Disconnect both the suction piping and the air discharge tubing from the priming chamber assembly (3). Support the priming chamber assembly using a sling and a suitable lifting device. Remove the hardware (4 and 5) and separate the priming chamber assembly, gasket (8) and baffle (7) from the pump assembly.

(Figure 5)

Remove the hardware (2 and 3) securing the priming valve (1) to the priming chamber (5). Carefully lift the valve components from the priming chamber. Remove the gasket (4) and clean the mating surfaces.

If the priming valve float is stuck or the strainer (6) is clogged, it can usually be cleaned without further disassembly.

The only serviceable part of the priming valve is the orifice button (not shown). If liquid continues to bypass through the priming chamber after adjusting the orifice button (see **Priming Chamber Re-assembly and Installation** for adjustment), the button may require replacement. To replace the orifice button, remove one of the “e-clips” from the pivot pin closest to the orifice button and remove the pivot pin. This will allow the linkage to be raised high enough to access the orifice button.

Remove the hex nut and lock washer securing the orifice button to the linkage bar and unscrew the orifice button from the linkage bar.

Discharge Check Valve Removal and Disassembly

(Figure 1)

Support the discharge check valve assembly (39) using a sling and a suitable lifting device. Remove the mounting hardware (not shown) and separate the discharge check valve assembly and gasket from the pump assembly (1).

The flapper and cover O-ring are the only serviceable parts of the check valve. If the flapper requires replacement, remove the hardware securing the cover. Separate the cover and O-ring and remove the flapper.

Pump Casing and Wear Ring Removal

(Figure 1)

The wear ring (3) may be serviced by removing the pump casing (1).

It is not necessary to remove the suction spool (32) from the pump casing unless replacement of the spool or gasket (28) is required. To remove the suction spool, disengage the hardware (8 and 9) securing it to the pump casing. Disengage the hardware (16 and 31) securing the suction spool to the suction support (30). Use a sling and suitable lifting device to remove the suction spool. Remove the gasket and clean the mating surfaces.

Disengage the hardware (8 and 9) and use a suitable lifting device to separate the pump casing from the rotating assembly (7).

Inspect the wear ring for excessive wear or damage. The wear ring is secured in the pump casing by a press fit. If replacement is required, remove the set screws (4) and install two 3/8–16 UNC–2B capscrews (not supplied) at least 1–1/4 inches long in the holes in the wear ring. Tighten the capscrews in an alternating sequence to “jack” the wear ring from the pump casing.

Impeller and Wear Ring Removal

(Figure 2)

Before attempting to remove the impeller (5) position a **clean** container (2 gallons [8 liters] minimum capacity) under the seal cavity drain plug (22). Re-

move the plug and drain the oil from the seal cavity into the container. Clean and reinstall the drain plug. Inspect the oil for water, dirt or a cloudy condition which could indicate seal failure.

Use an impact wrench and a suitably sized allen wrench to remove the impeller capscrew (1). Remove the impeller washers (2 and 3) from the shaft.

Install two 3/8—16 UNC—2B capscrews (not supplied) in the tapped holes in the impeller. Attach a suitable puller to the capscrews and use the puller to remove the impeller and key (32) from the shaft. Remove the puller and the screws from the impeller.

Inspect the wear ring (9) for excessive wear or damage. The wear ring is secured in the seal plate (11) by a press fit. If replacement is required, remove the set screws (10) and install two 3/8—16 UNC—2B capscrews (not supplied) at least 1—1/4 inches long in the holes in the wear ring. Tighten the capscrews in an alternating sequence to “jack” the wear ring from the seal plate.

Seal Removal

(Figures 2 and 9)

Carefully remove the spring retainer and seal spring. Slide the rotating portion of the seal assembly and shaft sleeve (7) off the shaft as a single unit. Remove the shaft sleeve O-ring (8). Apply oil to the shaft sleeve and work it up under the rubber bellows. Slide the rotating portion of the seal assembly off the shaft sleeve.

Slide a pair of stiff wires with hooked ends along the shaft and hook the stationary seat from the back side. Pull the stationary seat and O-ring from the seal plate (11).

An alternate method of removing the stationary seal components is to remove the hardware (16 and 17) and separate the seal plate from the pedestal (18). Position the seal plate on a flat surface with the impeller side down. Use a wooden dowel or other suitable tool to press on the back side of the stationary seat until the seat and O-ring can be removed.

Remove the seal plate O-ring (15).

If no further disassembly is required, refer to **Seal Reassembly And Installation**.

Air Compressor Removal

(Figure 1)

Further disassembly of the pump requires removing the air compressor assembly (13) from the rotating assembly (7).

Disengage the hardware (11) and remove the belt guard assembly (12).

Remove the hardware (16, 17 and 18) securing the air compressor assembly to the mounting flange (23, Figure 2). Use a pry bar to raise the air compressor high enough to remove the spacers (20, Figure 3). Remove the belt (10) from the air compressor drive pulley (not shown).

Disconnect all hoses and fittings from the air compressor and use a suitable hoist and sling to remove the air compressor assembly.

Separating Rotating Assembly From Power Source

(Figure 1)

The pump and drive assembly must be separated from the engine before further disassembly.

Disengage the hardware (11) and remove the belt guard assembly (12).

See Figure 3 and remove the hardware (16, 17, 18 and 19) securing the air compressor assembly (1) to the bracket (13). Use a pry bar to raise the air compressor high enough to remove the spacers (20).

Remove the belt (10) from the air compressor drive pulley (not shown). Remove the hardware (24 and 25) securing the pedestal (18, Figure 2) to the support assembly (26).

Support the pedestal using a hoist and sling and remove the coupling from the impeller shaft (31, Figure 2).

Move the pedestal to a clean, well equipped shop area for further disassembly.

Remove any leveling shims used under the pedestal mounting feet. Tie and tag the shims for ease of reassembly.

Remove the capscrews from the center of the bushing (15). Reinstall the capscrews in the tapped holes in the bushing and tighten them in an alternating pattern until the bushing is “jacked” out of the sprocket (14). Slide the bushing and sprocket off the shaft. Remove the key (30, Figure 2).

Shaft and Bearing Removal and Disassembly

(Figure 2)

When the pump is properly operated and maintained, the shaft and bearings should not require disassembly. Disassemble the shaft and bearings **only** when there is evidence of wear or damage.



Shaft and bearing disassembly in the field is not recommended. These operations should be performed only in a properly equipped shop by qualified personnel.

NOTE

There are no provisions for draining the lubricant from the pedestal. Place a drip pan under the pedestal before disassembly.

If not removed with the seal assembly, remove the hardware (16 and 17) and separate the seal plate and O-ring (15) from the pedestal (18).

Disengage the hardware (16 and 17) and remove the drive flange (23), gasket (25) and oil seal (24). Press the oil seal from the drive flange.

Place a block of wood against the impeller end of the shaft (31) and tap the shaft and assembled bearings (28 and 33) from the bearing housing.

Press the oil seals (19) from the bearing housing.

After removing the shaft and bearings, clean and inspect the bearings **in place** as follows.



To prevent damage during removal from the shaft, it is recommended that bearings

be cleaned and inspected **in place**. It is **strongly** recommended that the bearings be replaced **any** time the shaft and bearings are removed.

Clean the pedestal, shaft and all component parts (except the bearings) with a soft cloth soaked in cleaning solvent. Inspect the parts for wear or damage and replace as necessary.



Most cleaning solvents are toxic and flammable. Use them only in a well ventilated area free from excessive heat, sparks, and flame. Read and follow all precautions printed on solvent containers.

Clean the bearings thoroughly in **fresh** cleaning solvent. Dry the bearings with filtered compressed air and coat with light oil.



Bearings must be kept free of all dirt and foreign material. Failure to do so will greatly shorten bearing life. **Do not** spin dry bearings. This may scratch the balls or races and cause premature bearing failure.

Rotate the bearings by hand to check for roughness or binding and inspect the bearing balls. If rotation is rough or the bearing balls are discolored, replace the bearings.

The bearing tolerances provide a tight press fit onto the shaft and a snug slip fit into the pedestal. Replace the bearings, shaft, or pedestal if the proper bearing fit is not achieved.

If bearing replacement is required, straighten the tab on the bearing lock washer (27). Use a spanner wrench to remove the bearing lock nut (26). Remove the bearing lock washer.

Use a bearing puller to remove the inboard and outboard bearings from the shaft.

Shaft and Bearing Reassembly and Installation

(Figure 2)

Clean and inspect the bearings as indicated in **Shaft and Bearing Removal and Disassembly**.

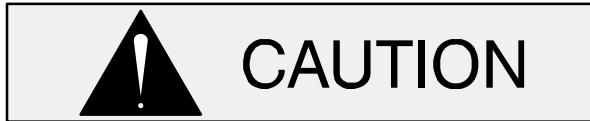

To prevent damage during removal from the shaft, it is recommended that bearings be cleaned and inspected **in place**. It is **strongly** recommended that the bearings be replaced **any** time the shaft and bearings are removed.

Inspect the shaft (31) for distortion, nicks or scratches. Dress small nicks and burrs with a fine file or emery cloth. Replace the shaft if defective.

The bearings may be heated to ease installation. An induction heater, hot oil bath, electric oven, or hot plate may be used to heat the bearing. The bearings should **never** be heated with a direct flame or directly on a hot plate.

NOTE

*If a hot oil bath is used to heat the bearings, both the oil and the container must be **absolutely** clean. If the oil has been previously used, it must be **thoroughly** filtered.*

NOTE

*Position the outboard bearing (22) on the shaft with the retaining ring on the bearing O.D. **toward the drive end of the shaft**. The inboard bearing (26) is equipped with a flange ring that is shipped loose with the bearing. Install the flange ring on the shaft prior to heating and installing the bearings.*

Heat the bearings to a uniform temperature **no higher than 250°F (120°C)** and slide them one at a time onto the shaft until fully seated against the shaft shoulders. This should be done quickly, in one continuous motion, to prevent the bearings from cooling and sticking on the shaft.



When installing the bearings onto the shaft, **never** press or hit against the outer race, balls, or ball cage. Press **only** on the inner race.

After installation, pack the bearings by hand with lithium EP2 grease until fully lubricated.

Slide the shaft and assembled bearings into the pedestal until the inboard bearing is fully seated against the bearing retaining ring.



It is recommended that a new bearing lock washer (27) be installed any time the shaft and bearings are disassembled. Re-use of an old lock washer may create a pre-load condition on the bearing, resulting in premature bearing failure.

Install the bearing lockwasher (27) and screw the bearing locknut (26) onto the shaft until tight. Torque the bearing lock nut to 150 ft. lbs. (20,8 m. kg.). After torquing, locate the tab on the lock washer that aligns with a slot in the lock nut and bend the tab over into the slot.

Apply a light coating of oil to the lip of the inboard oil seal (19) and press it into the pedestal bore with the lip positioned as shown in Figure 5. Press the oil seal into the pedestal until the face is **just flush** with the machined surface on the pedestal.

It is recommended that a sleeve be positioned against the inboard oil seal to prevent the lip of the oil seal from rolling as the shaft and bearings are installed in the pedestal. The O.D. of the sleeve should be just smaller than the bearing housing bore, while the I.D. of the sleeve should be just larger than the O.D. of the lip seal area of the shaft.

With the lip seal sleeve in place, lubricate the lip seal area of the shaft and slide the shaft and assembled bearings into the bearing housing until the retaining ring on the outboard bearing seats against the pedestal. Remove the lip seal sleeve.

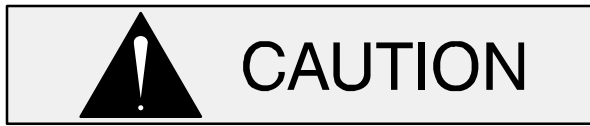

When installing the shaft and bearings into the bearing bore, push against the outer race. **Never** hit the balls, rollers or cages.

Apply a light coating of oil to the lip of the outboard oil seal (19) and press it into the pedestal with the lip positioned as shown in Figure 5. The face of the oil seal should be **just flush** with the outer face of the bearing cap.

Install the shaft key (30) in the shaft keyway. Slide the bushing and sprocket (8 and 9) onto the shaft to the dimension shown in Figure 8. Install the bushing setscrews and tighten the setscrews in an alternating sequence to secure the sprocket to the shaft. Torque the setscrews to 66.7 ft. lbs. (800 in. lbs. or 9,2 m. kg.).

Apply a light coating of oil to the lip of the oil seal (24) and press it into the drive flange (23) with the lip positioned as shown in Figure 5. The face of the oil seal should be just flush with the outer face of the bearing cap. Inspect and remove any sealant shavings from the O.D. of the lip seal.

Install the gasket (25) and slide the assembled drive flange and oil seal over the impeller shaft. Use caution not to cut or roll the lip of the oil seal (24) on the shaft keyway. Secure the drive flange to the pedestal with the hardware (16 and 17). Torque the capscrews (16) initially to 80 ft. lbs. (11 m. kg.) in a criss-cross pattern, then torque the capscrews again to 110 ft. Lbs (15,2 m. kg.) in a criss-cross pattern, going around the bolt circle 1-1/2 times.

Lubricate the pedestal as indicated in **LUBRICATION** at the end of this section.

Securing Rotating Assembly to Power Source

(Figure 1)

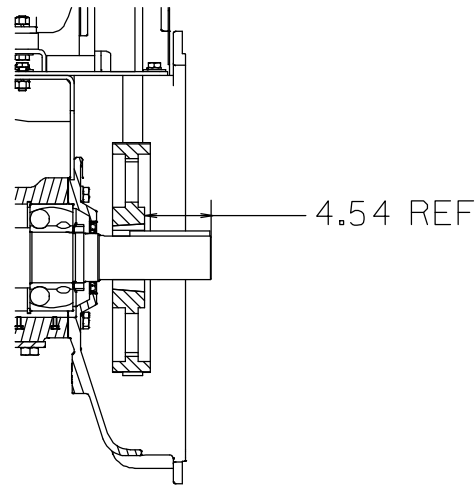

Figure 8. Drive Sprocket Positioning

Position the drive belt (10) over the sprocket (14) and slide it up through the slot in the drive flange (23, Figure 2).

Using a suitable lifting device, position the assembled pedestal on the pedestal support (26) and secure the pedestal with the attaching hardware (24 and 25). Be sure to install any leveling shims used under the pedestal feet.

(Figure 3)

Slide the air compressor drive belt (10, Figure 1) over the air compressor sprocket (11). Use a pry bar to raise the air compressor (1) high enough to install the spacers (20). Secure the air compressor to the bracket (13) with the previously removed hardware (16, 17, 18 and 19).

Seal Reassembly and Installation

(Figures 2 and 9)

Clean the seal cavity and shaft with a cloth soaked in fresh cleaning solvent. Inspect the stationary seat bore in the seal plate for dirt, nicks and burrs, and remove any that exist. The stationary seat bore **must** be completely clean before installing the seal.



Most cleaning solvents are toxic and flammable. Use them only in a well ven-

tilated area free from excessive heat, sparks, and flame. Read and follow all precautions printed on solvent containers.

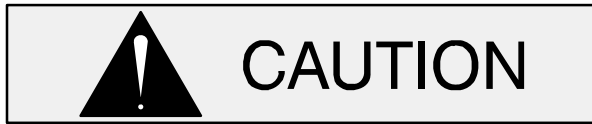

A new seal assembly should be installed **any time** the old seal is removed from the pump. Wear patterns on the finished faces cannot be realigned during reassembly. Reusing an old seal could result in premature failure.

Handle the seal parts with extreme care to prevent damage. Be careful not to contaminate precision finished faces; even fingerprints on the faces can shorten seal life. If necessary, clean the faces with a

non-oil based solvent and a clean, lint-free tissue. Wipe **lightly** in a concentric pattern to avoid scratching the faces.

Inspect the seal components for wear, scoring, grooves, and other damage that might cause leakage. Clean and polish the shaft sleeve, or replace it if there are nicks or cuts on either end. If any components are worn, replace the complete seal; **never mix old and new seal parts.**

Remove the seal from the container and inspect the precision finished faces to ensure that they are free of any foreign matter.

To ease installation of the seal, lubricate the stationary seat O-ring, the I.D. of the bellows and the O.D. of the shaft sleeve (5) with "P-80[®] Emulsion" or water. **Do not** use oil or any substitute lubricant other than water. Apply a drop of light lubricating oil on the finished faces. Assemble the seal as follows, (see Figure 9).

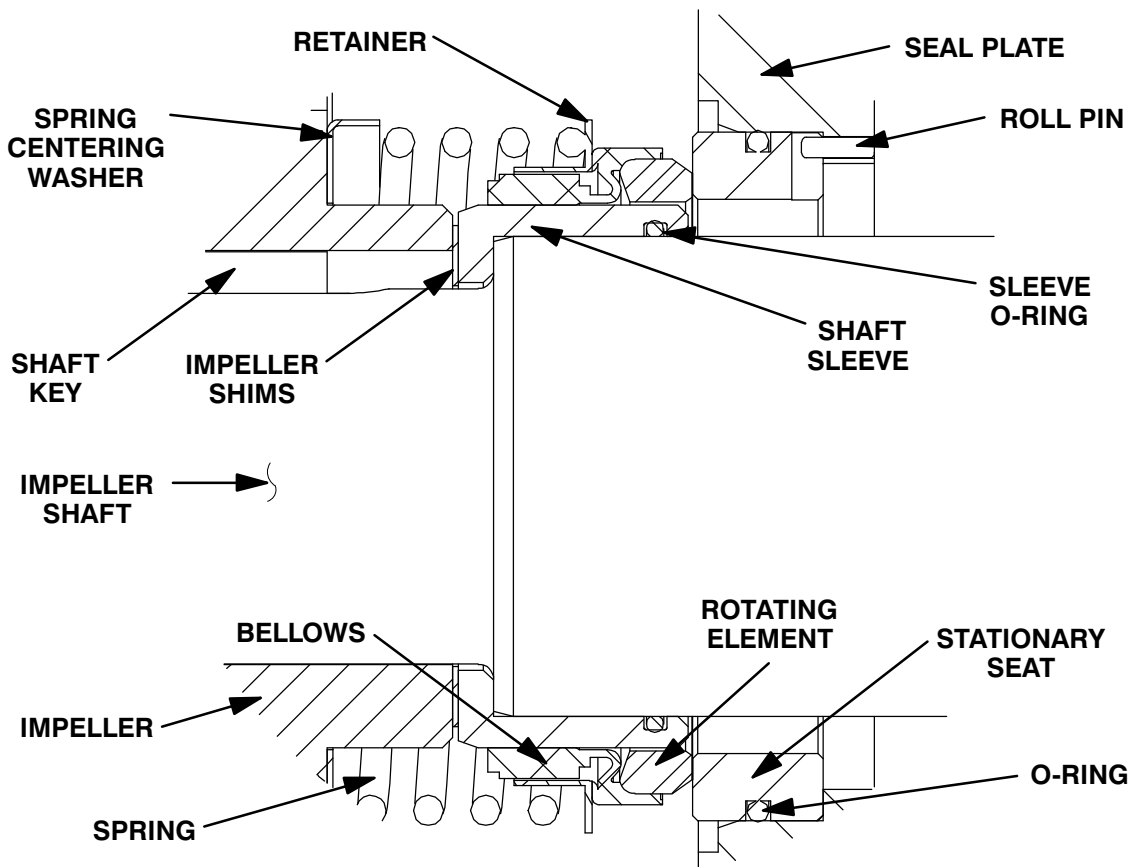
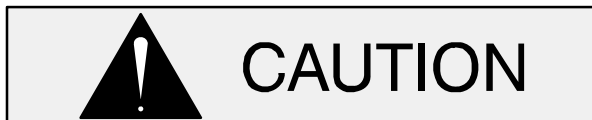

Figure 9. Seal Assembly



This seal is not designed for operation at

temperatures above 160°F (71°C). Do not use at higher operating temperatures.

Inspect the seal plate (11), shaft sleeve (7) and the impeller shaft for burrs or sharp corners, and remove any that exist.

If the wear ring (9) was removed, press the replacement ring into the seal plate until fully seated. Apply “Loctite Threadlocker No. 243” or equivalent compound to the threads of the setscrews (10) and install them in the holes in the wear ring until snug.

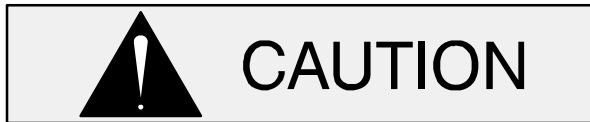

The wear ring **must** seat squarely in the seal plate bore; otherwise binding and/or excessive wear will occur as the shaft turns.

Position the seal plate over the pedestal shoulder and secure the seal plate to the pedestal with the previously removed hardware (16 and 17). If a new seal plate is being installed, position the roll pin (4) in the hole in the seal plate bore and tap it into place with a hammer until fully seated.

Align the notch in the stationary seal seat with the roll pin (4) and press the stationary seat and its O-ring into the seal plate until fully seated in the seal plate bore. A push tube cut from a length of plastic pipe would aid this process. The I.D. of the tube should be slightly larger than the O.D. of the shaft sleeve (7).

Install the shaft sleeve O-ring (8) in the groove in the I.D. of the sleeve. Lubricate the O-ring and the O.D. of the shaft sleeve with “P-80[®] Emulsion” or water. **Do not** use oil or any substitute lubricant other than water.

Slide the rotating subassembly (consisting of the rotating element, retainer and bellows) onto the sleeve until the rotating element is **just flush** with the chamfered end of the sleeve. Slide the shaft sleeve and rotating subassembly onto the shaft until the seal faces contact and the shaft sleeve seats against the shoulder on the impeller shaft. Install the seal spring and spring centering washer.

After the impeller has been installed, lubricate the seal as indicated in **LUBRICATION**.

Impeller Installation

(Figure 2)

Inspect the impeller and replace it if cracked or badly worn. If removed, install the roll pin (4) in the hole in the impeller hub.

Install the impeller key (32) in the shaft keyway. Align the keyway in the impeller with the impeller key and press the impeller onto the shaft until fully seated.

Use a piece of soft bar stock or a wood block to prevent impeller rotation. Align the hole in the impeller washer (3) with the roll pin in the impeller and install the washer. Apply “Loctite Threadlocker No. 243” or equivalent compound to the threads of the impeller screw (1). Install the impeller screw and torque the screw to 300 ft. lbs. (41,5 m. kg.). Remove the wood block or metal bar used to prevent impeller rotation.

Pump Casing and Wear Ring Installation

(Figure 1)

If the wear ring (3) was removed, press the replacement ring into the pump casing until fully seated. Apply “Loctite Threadlocker No. 243” or equivalent compound to the threads of the setscrews (4) and install them in the holes in the wear ring until snug.



The wear ring **must** seat squarely in the pump casing or binding and/or excessive wear will result.

Lubricate the O-ring (5) with light grease and install it in the groove in the O.D. of the seal plate.

Carefully position the pump casing over the impeller. Install the hardware (8 and 9) on the studs (6) and use the hardware to draw the pump casing over the seal plate shoulder until tight.

If removed at disassembly, install the gasket (28) over the studs (29) and secure the suction spool (32) to the pump casing with the previously removed hardware (8 and 9).

Secure the suction spool to the support assembly (30) with the previously removed hardware (16 and 31).

Discharge Check Valve Reassembly and Installation

(Figure 1)

If the discharge check valve (39) was disassembled to replace the flapper or cover O-ring, position the flapper in the valve body and check to ensure free movement.

Install the valve cover O-ring and secure the cover to the body with the previously removed hardware.

Apply a small amount of light grease to the discharge flange gasket to hold it in place and position it against the pump casing flange. Support the discharge check valve assembly using a sling and a suitable lifting device. Using the previously removed hardware, secure the discharge check valve assembly and flange gasket to the pump assembly (1). Secure the discharge check valve to its support bracket using the previously removed hardware.

Priming Chamber Assembly and Installation

(Figure 5)

Clean and inspect the components of the priming valve (1). Inspect the linkage and ensure the orifice button (not shown) squarely engages the valve seat. Replace the orifice button if required (see **Priming Chamber Removal and Disassembly** for orifice button removal).

If the orifice button was removed, screw the new orifice button into the linkage bar until fully seated. Align the hole in the linkage bar with the holes in the bracket and reinstall the pivot pin. Secure the pivot pin with the previously removed "e-clip".

Adjust the orifice button seating as necessary by screwing the orifice button into or out of the linkage bar. Proper adjustment is achieved when the orifice button fully seats against the orifice before the linkage bar on the float bottoms against the threads on the orifice button. When adjustment is complete, install and tighten the lock washer and hex nut securing the orifice button.

Install the strainer (6) and priming valve gasket (4).

Lower the float into the priming chamber (5) and secure the priming valve with the previously removed hardware (2 and 3).

(Figure 4)

Install the baffle and gasket (7 and 8) and use a sling and suitable lifting device to position the prim-

ing chamber assembly on the pump suction spool (32, Figure 1). Secure the priming chamber assembly with the hardware (4 and 5).

Reconnect both the suction piping and the air discharge tubing to the priming chamber assembly.

LUBRICATION

Seal Assembly

(Figure 2)

Before starting the pump, remove the air vent and reducer bushing (14 and 12) and fill the seal cavity with approximately 220 ounces (6,5 liters) of SAE No. 30 non-detergent oil to the middle of the sight gauges (13) and maintain it at the middle of the gauges. Clean and reinstall the air vent and bushing. Maintain the oil at this level.

Bearings

(Figure 2)

The pedestal was fully lubricated when shipped from the factory. The grease fittings (20) are protected from contamination by the cap plugs (21). Remove the cap plugs and clean the grease fittings **thoroughly** before adding grease. After lubricating the bearings, clean the fittings and reinstall the cap plugs.

Under normal conditions, re-lubricate the bearings after every 1500 hours of use by adding 1 oz. (28 g.) of lithium EP2 grease to the impeller end bearing and 2 oz. (56 g.) of grease to the drive end bearing. **Do not** over-lubricate. Over-lubrication can cause the bearings to over-heat, resulting in premature bearing failure.

When lubricating a **new** bearing pedestal, pack the bearings by hand with lithium EP2 grease until fully lubricated prior to installing the shaft and bearings into the pedestal. After installing the shaft and bearings into the pedestal, lubricate the bearings as follows:

Impeller End Bearing: 6 oz. (170 g) each fitting

Drive End Bearing: 11 oz. (312 g) each fitting

Power Source

Consult the literature supplied with the power source, or contact your local power source representative.

**For Warranty Information, Please Visit
www.grpumps.com/warranty
or call:
U.S.: 419-755-1280
Canada: 519-631-2870
International: +1-419-755-1352**

GORMAN-RUPP PUMPS