

Gasoline Engine Driven



Self Priming Centrifugal Pump

Models 12D-GX160 and 12D1-GX160

Size 2" x 2"



Total Head		Capacity Of Pump In U.S. Gallons Per Minute (GPM) At Continuous Performance				
P.S.I.	Feet					
46.0	106	46	46	46	46	46
43.3	100	64	64	64	64	64
39.0	90	76	92	92	92	92
34.7	80	81	104	120	120	120
30.3	70	82	109	130	142	143
26.0	60	82	110	132	152	161
21.7	50	82	110	132	154	173
17.3	40	82	110	133	155	178
13.0	30	83	110	133	155	180
Suction Lift		25'	20'	15'	10'	5'



PUMP SPECIFICATIONS

- Size:** 2" x 2" (51 mm x 51 mm) NPT - Female.
- Casing:** Aluminum Alloy 356-T6 w/Gray Iron 30 Cutwater Insert. Maximum Operating Pressure 76 psi (524 kPa).*
- Semi-Open Type, Two Vane Impeller:** Ductile Iron 65-45-12. Handles 1 3/16" (30,2 mm) Diameter Spherical Solids.
- Replaceable Wear Plate:** Carbon Steel ASTM A36.
- Removable Cover Plate:** Aluminum Alloy 356-T6; 4 lbs. (1,8 kg).
- Intermediate Bracket:** Gray Iron 30.
- Seal:**
 - (12D)** Double, Grease-Lubricated w/Spring-Loaded Grease Cup. Sintered Bronze Stationary Seal Seats. Steel Rotating Faces. Neoprene Packing Rings. Maximum Temperature of Liquid Pumped, 110°F (43°C). Maximum Suction Pressure 10 psi (69 kPa).*
 - (12D1)** Type 31, Mechanical, Self-Lubricated. Silicon Carbide Rotating and Stationary Faces. Fluorocarbon Elastomers (DuPont Viton® or Equivalent). Stainless Steel 316 Cage and Spring. Maximum Temperature of Liquid Pumped 160°F (71°C).*
- Shaft Liner: (12D)** Copper Alloy C26000.
- Shaft Sleeve: (12D1)** 304 Stainless Steel.
- Flap Valve:** Buna-N with Nylon Reinforcement; Gray Iron 30 and Sintered Powdered Steel 35.
- Suction Flange:** Aluminum Alloy 356-T6.
- Gaskets:** Cork with Nitrile Binder (NC710) and Vegetable Fiber.
- Hardware:** Standard Plated Steel.
- Roll Cage with Rubber Feet.**
- 90° Discharge Elbow.**
- Strainer.**

Optional Equipment: Wheel Kit w/Semi-Pneumatic Tires.

**Consult Factory for Applications Exceeding Maximum Pressure and/or Temperature Indicated.*

WARNING!

Do not use in explosive atmosphere or for pumping volatile flammable liquids.

ENGINE SPECIFICATIONS

- Model:** Honda GX160.
- Type:** Single Cylinder, Four Cycle, Air Cooled, Overhead Valve, Gasoline Engine.
- Displacement:** 9.9 Cu. In. (163 cc).
- Carburetor:** Horizontal Type.
- Lubrication:** Splash System.
- Air Cleaner:** Dual Element, Dry Type.
- Fuel Tank:** 3.8 U.S. Qts. (3,6 liter).
- Full Load Operating Time:** 2.0 Hrs.
- Starter:** Rope Rewind.

Standard Features: Muffler w/Guard. Manual Rotary Stop Switch. Manual Choke and Throttle Control w/Top Speed Limit. "Oil Alert"™ Low Oil Shut Down. Transistorized Magneto Ignition.



GORMAN-RUPP PUMPS

www.grpumps.com

Specifications Subject to Change Without Notice

Printed in U.S.A.

Specification Data

APPROXIMATE DIMENSIONS and WEIGHTS

NET WEIGHT: 85 LBS. (39 KG.)
SHIPPING WEIGHT: 95 LBS. (43 KG.)
EXPORT CRATE: 5.6 CU. FT. (0,16 CU. M.)
WHEEL KIT ADD 25 LBS. (11,3 KG.);
SHIPPING CRATE (SEPARATE) 3 CU. FT. (0,1 CU. M.)

SECTION 45, PAGE 527

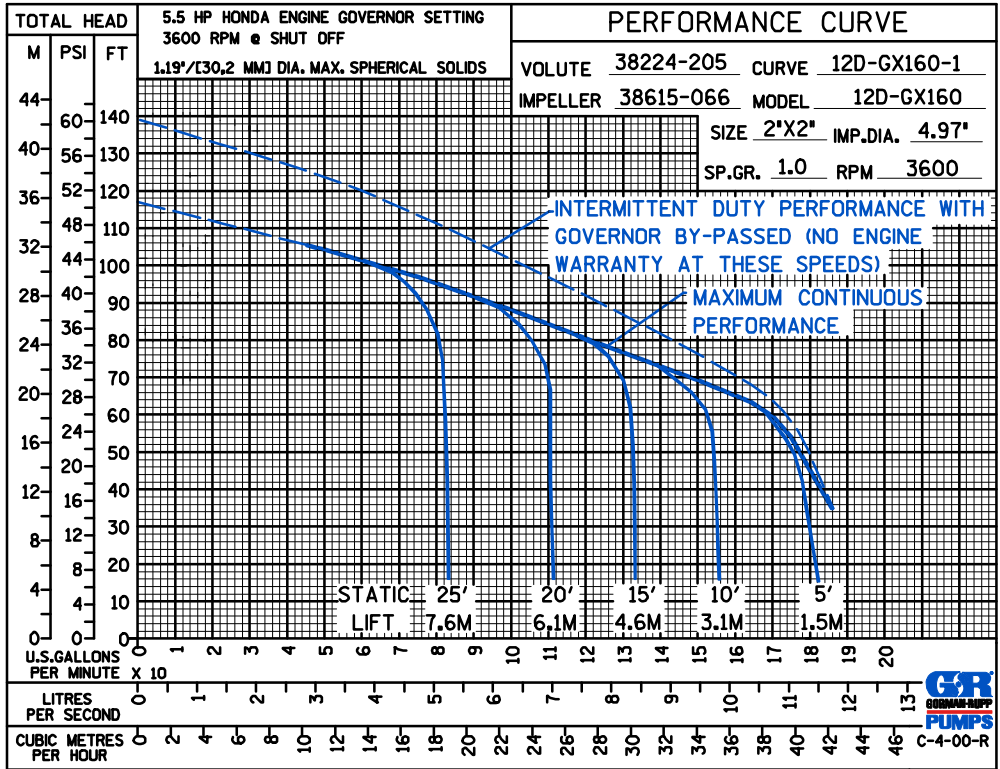
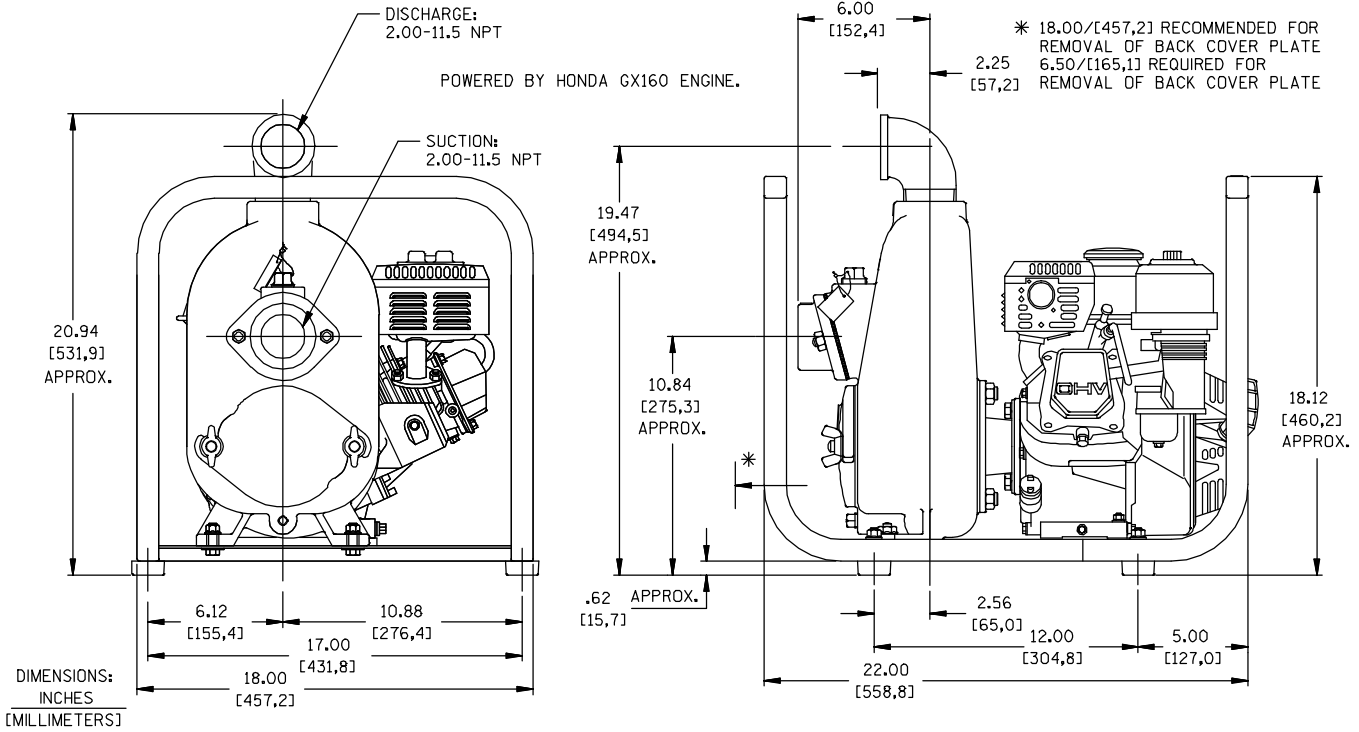

GORMAN-RUPP PUMPS

www.grpumps.com

Specifications Subject to Change Without Notice

Printed in U.S.A.