

---

**INSTALLATION, OPERATION,  
AND MAINTENANCE MANUAL**  
WITH PARTS LIST



**0 SERIES PUMPS**

MODEL
<b>04B52-B</b>

**THE GORMAN-RUPP COMPANY • MANSFIELD, OHIO**  
GORMAN-RUPP OF CANADA LIMITED • ST. THOMAS, ONTARIO, CANADA Printed In U.S.A.

## TABLE OF CONTENTS

INTRODUCTION . . . . .	I-1
WARNINGS - SECTION A . . . . .	A-1
INSTALLATION - SECTION B . . . . .	B-1
Pump Dimensions . . . . .	B-1
PREINSTALLATION INSPECTION . . . . .	B-2
POSITIONING PUMP . . . . .	B-3
Lifting . . . . .	B-3
Mounting . . . . .	B-3
SUCTION AND DISCHARGE PIPING . . . . .	B-4
Materials . . . . .	B-4
Line Configuration . . . . .	B-4
Connections to Pump . . . . .	B-4
Gauges . . . . .	B-4
SUCTION LINES . . . . .	B-4
Fittings . . . . .	B-5
Strainers . . . . .	B-5
Sealing . . . . .	B-5
Suction Lines In Sumps . . . . .	B-5
Suction Line Positioning . . . . .	B-6
DISCHARGE LINES . . . . .	B-6
Siphoning . . . . .	B-6
Valves . . . . .	B-7
Bypass Lines . . . . .	B-7
ALIGNMENT . . . . .	B-7
Coupled Drives . . . . .	B-8
V-Belt Drives . . . . .	B-9
OPERATION - SECTION C . . . . .	C-1
PRIMING . . . . .	C-1
STARTING . . . . .	C-2
Rotation . . . . .	C-2
OPERATION . . . . .	C-3
Lines With a Bypass . . . . .	C-3
Lines Without a Bypass . . . . .	C-3
Leakage . . . . .	C-3
Liquid Temperature And Overheating . . . . .	C-3
Strainer Check . . . . .	C-4
Pump Vacuum Check . . . . .	C-4
STOPPING . . . . .	C-4
Cold Weather Preservation . . . . .	C-5
BEARING TEMPERATURE CHECK . . . . .	C-5
PUMP TROUBLESHOOTING - SECTION D . . . . .	D-1
PUMP MAINTENANCE AND REPAIR - SECTION E . . . . .	E-1
PERFORMANCE CURVE . . . . .	E-1
PUMP MODEL - PARTS LIST . . . . .	E-3
PUMP AND SEAL DISASSEMBLY AND REASSEMBLY . . . . .	E-4
Pump Disassembly . . . . .	E-4
Impeller Removal . . . . .	E-5
Seal Disassembly . . . . .	E-5
Shaft And Bearing Removal And Disassembly . . . . .	E-5
Shaft And Bearing Reassembly And Installation . . . . .	E-6
Seal Installation . . . . .	E-7
Pump Reassembly . . . . .	E-9
Final Pump Reassembly . . . . .	E-10
LUBRICATION . . . . .	E-10
Seal Assembly . . . . .	E-10
Bearings . . . . .	E-10



This Installation, Operation, and Maintenance Manual is designed to help you achieve the best performance and longest life from your Gorman-Rupp pump.

This pump is an O Series, closed impeller, self-priming centrifugal model. The pump is designed without a suction check valve and is suitable for pumping most non-volatile, non-flammable liquids containing specified entrained solids and/or abrasives. The basic material of construction for wetted parts is gray iron, with an alloy steel impeller shaft.

If there are any questions regarding the pump or its application which are not covered in this manual or in other literature accompanying this unit, please contact your Gorman-Rupp distributor, or write:

The Gorman-Rupp Company	or	Gorman-Rupp of Canada Limited
P.O. Box 1217		70 Burwell Road
Mansfield, Ohio 44901		St. Thomas, Ontario N5P 3R7

For information or technical assistance on the power source, contact the power source manufacturer's local dealer or representative.

The following are used to alert maintenance personnel to procedures which require special attention, to those which could damage equipment, and to those which could be dangerous to personnel:

**NOTE**

Instructions to aid in installation, operation, and maintenance or which clarify a procedure.

**CAUTION**

Instructions which must be followed to avoid causing damage to the product or other equipment incidental to the installation. These instructions describe the requirements and the possible damage which could result from failure to follow the procedures.

**WARNING**

```

////////////////////////////////////
//
// These instructions must be followed to avoid causing in- //
// jury or death to personnel, and describe the procedure //
// required and the injury which could result from failure //
// to follow the procedure. //
// //
////////////////////////////////////

```



WARNINGS - SECTION A

THESE WARNINGS APPLY TO 0 SERIES BASIC PUMPS. GORMAN-RUPP HAS NO CONTROL OVER OR PARTICULAR KNOWLEDGE OF THE POWER SOURCE WHICH WILL BE USED. REFER TO THE MANUAL ACCOMPANYING THE POWER SOURCE BEFORE ATTEMPTING TO BEGIN OPERATION.

WARNING

```

////////////////////////////////////
//
// Before attempting to open or service the pump:
//
// 1. Familiarize yourself with this manual.
// 2. Disconnect or lock out the power supply to ensure
//    that the pump will remain inoperative.
// 3. Allow the pump to cool if overheated.
// 4. Vent the pump slowly and cautiously.
// 5. Close the suction and discharge valves.
// 6. Check the temperature before opening any covers,
//    plates, or plugs.
// 7. Drain the pump.
//
////////////////////////////////////

```

WARNING

```

////////////////////////////////////
//
// This pump is designed to pump liquids containing speci-
// fied entrained solids. Do not attempt to pump volatile,
// flammable or corrosive liquids which may damage the pump
// or endanger personnel as a result of pump failure.
//
////////////////////////////////////

```

WARNING

```

////////////////////////////////////
//
// After the pump has been positioned, make certain that
// the pump and all piping connections are tight , properly
// supported and secure before operation.
//
////////////////////////////////////

```

WARNING

```

////////////////////////////////////
//
// Do not operate the pump without shields and/or guards in
// place over rotating parts. Exposed rotating parts can
// catch clothing, fingers, or tools, causing severe injury
// to personnel.
//
////////////////////////////////////

```

WARNING

```
//////////////////////////////////////////////////////////////////////////////////////////////////////////////////////////////////  
//  
// Do not operate the pump against a closed discharge valve //  
// for long periods of time. This could bring the liquid //  
// to a boil, build pressure, and cause the pump to rupture //  
// or explode. //  
// //  
//////////////////////////////////////////////////////////////////////////////////////////////////////////////////////////////////
```

WARNING

```
//////////////////////////////////////////////////////////////////////////////////////////////////////////////////////////////////  
//  
// Overheated pumps can cause severe burns and injury. If //  
// overheating of the pump occurs: //  
// //  
// 1. Stop the pump immediately. //  
// 2. Allow the pump to cool. //  
// 3. Refer to instructions in this manual before re- //  
// starting the pump. //  
// //  
//////////////////////////////////////////////////////////////////////////////////////////////////////////////////////////////////
```

WARNING

```
//////////////////////////////////////////////////////////////////////////////////////////////////////////////////////////////////  
//  
// Do not remove plates, covers, gauges, pipe plugs, or //  
// fittings from an overheated pump. Vapor pressure within //  
// the pump can cause parts being disengaged to be ejected //  
// with great force. Allow the pump to cool before servic- //  
// ing. //  
// //  
//////////////////////////////////////////////////////////////////////////////////////////////////////////////////////////////////
```

---

---

## INSTALLATION - SECTION B

Since pump installations are seldom identical, this section offers only general recommendations and practices required to inspect, position, and arrange the pump and piping.

Most of the information pertains to a standard **static lift application** where the pump is positioned above the free level of liquid to be pumped.

If installed in a **flooded suction application** where the liquid is supplied to the pump under pressure, some of the information such as mounting, line configuration, and priming must be tailored to the specific application. Since the pressure supplied to the pump is critical to performance and safety, **be sure** to limit the incoming pressure to 50% of the maximum pressure developed by the pump.

For further assistance, contact your Gorman-Rupp distributor or the Gorman-Rupp Company.

### Pump Dimensions

See Figure 1 for the approximate physical dimensions of this pump.



## OUTLINE DRAWING

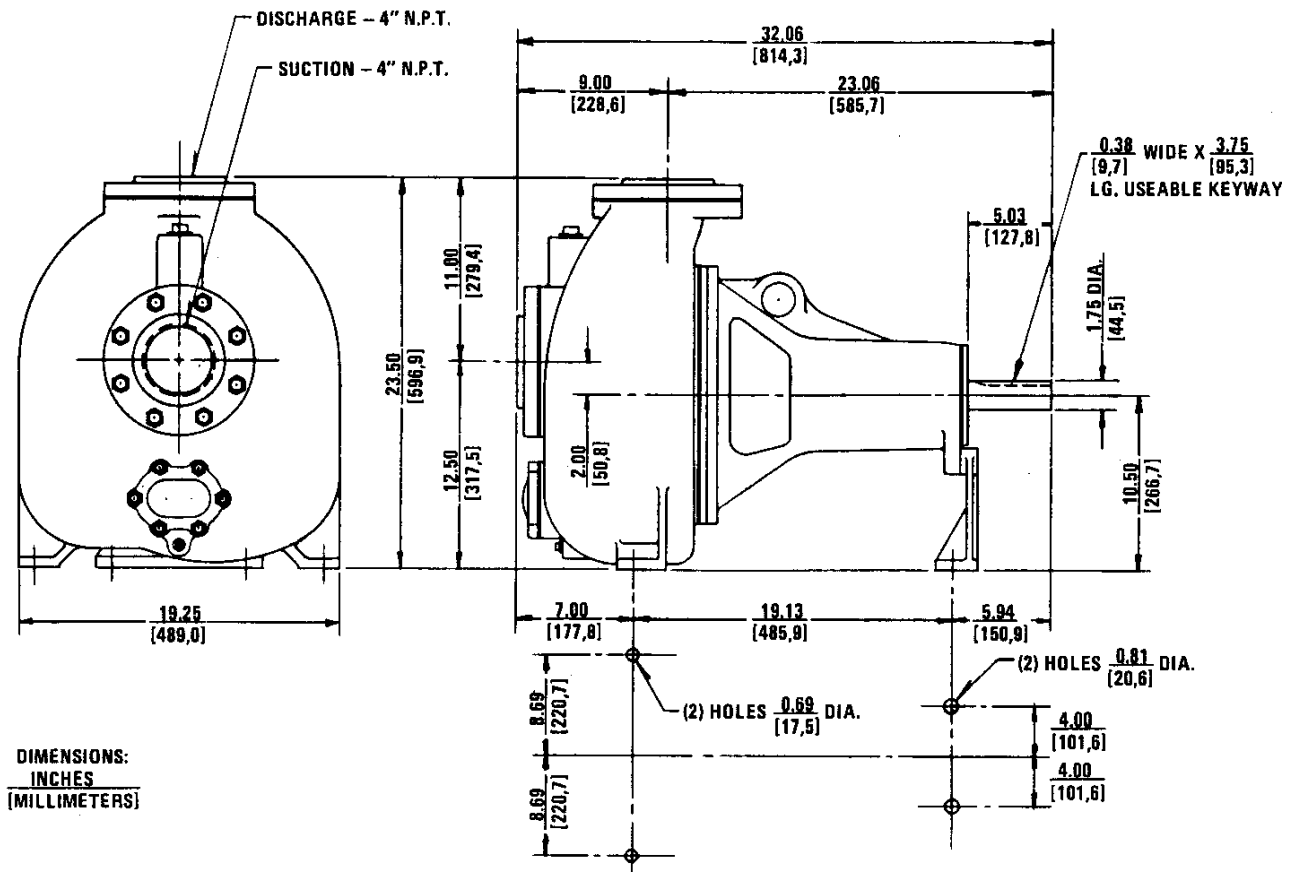

Figure 1. Pump Model 04B52-B

## PREINSTALLATION INSPECTION

The pump assembly was inspected and tested before shipment from the factory. Before installation, inspect the pump for damage which may have occurred during shipment. Check as follows:

- Inspect the pump for cracks, dents, damaged threads, and other obvious damage.
- Check for and tighten loose bolts, nuts, capscrews, and other attaching hardware. Since gaskets tend to shrink after drying, check for and tighten loose nuts and capscrews securing mating surfaces.
- Carefully read all warning and cautions contained in this manual, and perform all duties indicated. Note the direction of rotation indicated

---

---

on the pump. Check that the pump shaft rotates counterclockwise facing the pump suction.

#### CAUTION

Only operate this pump in the direction indicated by the arrow on the pump body and on the accompanying decal. Otherwise, the impeller could become loosened from the shaft and seriously damage the pump.

- d. Check all lubricant levels and lubricate as necessary. Refer to LUBRICATION in the MAINTENANCE AND REPAIR section of this manual and perform duties as instructed.
- e. If the pump and power source have been stored for more than 12 months, some of the components or lubricants may have exceeded their maximum shelf life. These **must be inspected or replaced** to ensure maximum pump service.

If the maximum shelf life has been exceeded, or if anything appears to be abnormal, contact your Gorman-Rupp distributor or the factory to determine the repair or updating policy. **Do not** put the pump into service until appropriate action has been taken.

### POSITIONING PUMP

#### Lifting

Use lifting equipment with a capacity of a least **2,200 pounds**. This pump weighs approximately **435 pounds**, not including the weight of accessories and mounting base with power source. Customer installed equipment such as suction and discharge piping **must** be removed before attempting to lift.

#### CAUTION

The pump assembly can be seriously damaged if the cables or chains used to lift and move the unit are improperly wrapped around the pump.

#### Mounting

Locate the pump in an accessible place as close as practical to the liquid being pumped. Level mounting is essential for proper operation. The pump may have to be supported or shimmed to provide for level operation or to eliminate vibration.

---

---

## SUCTION AND DISCHARGE PIPING

### Materials

Either pipe or hose may be used for suction and discharge lines; however, the materials must be compatible with the liquid being pumped. If hose is used in suction lines, it must be the rigid-wall, reinforced type to prevent collapse under suction. Using piping couplings in suction lines is not recommended.

### Line Configuration

Keep suction and discharge lines as straight as possible to minimize friction losses. Make minimum use of elbows and fittings, which substantially increase friction loss. If elbows are necessary, use the long-radius type to minimize friction loss.

### Connections to Pump

Before tightening a connecting flange, align it exactly with the pump port. Never pull a pipe line into place by tightening the flange bolts and/or couplings.

Lines near the pump must be independently supported to avoid strain on the pump which could cause excessive vibration, decreased bearing life, and increased shaft and seal wear. If hose-type lines are used, they should have adequate support to secure them when filled with liquid and under pressure.

### Gauges

Most pumps are drilled and tapped for installing discharge pressure and vacuum suction gauges. If these gauges are desired for pumps that are not tapped, drill and tap the suction and discharge lines not less than 18 inches from the suction and discharge ports and install the lines. Installation closer to the pump may result in erratic readings.

## SUCTION LINES

To avoid air pockets which could affect pump priming, the suction line must be as short and direct as possible. When operation involves a suction lift, the line must always slope upward to the pump from the source of the liquid being pumped; if the line slopes down to the pump at any point along the suction run, air pockets will be created.

---

---

## INSTALLATION

---

---

### Fittings

Suction lines should be the same size as the pump inlet. If reducers are used in suction lines, they should be the eccentric type, and should be installed with the flat part of the reducers uppermost to avoid creating air pockets. Valves are not normally used in suction lines, but if a valve is used, install it with the stem horizontal to avoid air pockets.

### Strainers

If a strainer is furnished with the pump, be certain to use it; any spherical solids which pass through a strainer furnished with the pump will also pass through the pump itself.

If a strainer is not furnished with the pump, but is installed by the pump user, make certain that the total area of the openings in the strainer is at least three or four times the cross section of the suction line, and that the openings will not permit passage of solids larger than the solids handling capability of the pump.

This pump is designed to handle up to 1/2 inch diameter spherical solids.

### Sealing

Since even a slight leak will affect priming, head, and capacity, especially when operating with a high suction lift, all connections in the suction line should be sealed with pipe dope to ensure an airtight seal. Follow the sealant manufacturer's recommendations when selecting and applying the pipe dope. The pipe dope should be compatible with the liquid being pumped.

### Suction Lines In Sumps

If a single suction line is installed in a sump, it should be positioned away from the wall of the sump at a distance equal to one and one-half times the diameter of the suction line.

If there is a liquid flow from an open pipe into the sump, the flow should be kept away from the suction inlet because the inflow will carry air down into the sump, and air entering the suction line will reduce pump efficiency.

If it is necessary to position inflow close to the suction inlet, install a baffle between the inflow and the suction inlet at a distance one and one-half times the diameter of the suction pipe. The baffle will allow entrained air to escape from the liquid before it is drawn into the suction inlet.

If two suction lines are installed in a single sump, the flow paths may interact, reducing the efficiency of one or both pumps. To avoid this, position the suction inlets so that they are separated by a distance equal to at least three times the diameter of the suction pipe.

Suction Line Positioning

The depth of submergence of the suction line is critical to efficient pump operation. Figure 2 shows recommended minimum submergence vs. velocity.

NOTE

The pipe submergence required may be reduced by installing a standard pipe increaser fitting at the end of the suction line. The larger opening size will reduce the inlet velocity. Calculate the required submergence using the following formula based on the increased opening size (area or diameter).

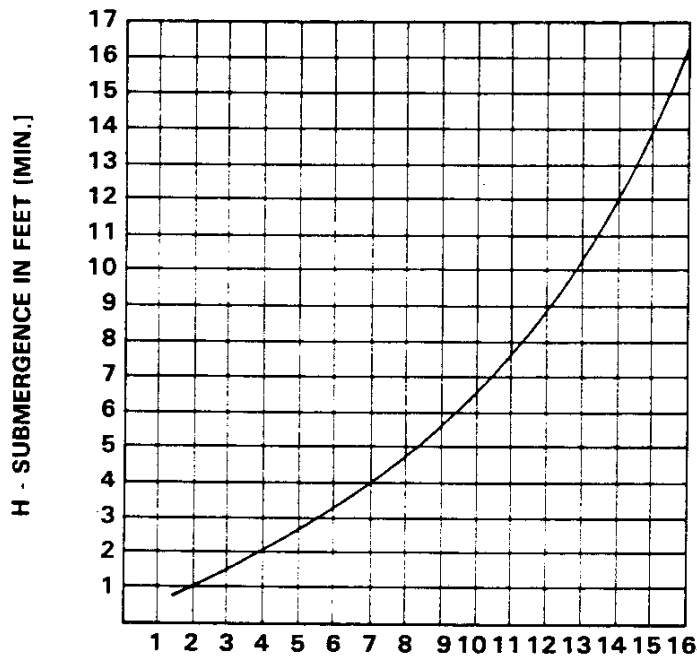

$$\text{VELOCITY IN FEET PER SEC.} = \frac{\text{QUAN. [G.P.M.] x .321}}{\text{AREA}} \text{ OR } \frac{\text{G.P.M. x .4085}}{D^2}$$

Figure 2. Recommended Minimum Suction Line Submergence Vs. Velocity

DISCHARGE LINES

Siphoning

Do not terminate the discharge line at a level lower than that of the liquid being pumped unless a siphon breaker is used in the line. Otherwise, a siphoning action causing damage to the pump could result.

---

---

## Valves

If a throttling valve is desired in the discharge line, use a valve as large as the largest pipe to minimize friction losses. Never install a throttling valve in a suction line.

With high discharge heads, it is recommended that a throttling valve and a system check valve be installed in the discharge line to protect the pump from excessive shock pressure and reverse rotation when it is stopped.

## Bypass Lines

If it is necessary to permit the escape of air to atmosphere during initial priming or in the repriming cycle, install a bypass line between the pump and the discharge check valve. The bypass line should be sized so that it does not affect pump discharge capacity.

Either a Gorman-Rupp automatic air release valve - which will automatically open to allow the pump to prime, and automatically close when priming is accomplished - or a hand-operated shutoff valve should be installed in the bypass line.

### NOTE

The bypass line may clog frequently, particularly if the valve remains closed. If this condition occurs, either use a larger bypass line or leave the shutoff valve open during the pumping operation.

Do not terminate the discharge line at a level lower than that of the liquid being pumped unless a siphon breaker is used in the line. Otherwise, a siphoning action could result, causing damage to the pump.

## ALIGNMENT

The alignment of the pump and its power source is critical for trouble-free mechanical operation. In either a flexible coupling or V-belt driven system, the driver and pump must be mounted so that their shafts are aligned with and parallel to each other. It is imperative that alignment be checked after the pump and piping are installed, and before operation.

### NOTE

Check **Rotation**, Section C, before final alignment of the pump.

When mounted at the Gorman-Rupp factory, driver and pump are aligned before shipment. Misalignment can occur in transit and handling. Pumps should be checked, and realigned if necessary, before being put into operation. Before checking alignment, tighten the foundation bolts. The pump casing feet and/or pedestal feet, and the driver mounting bolts should also be tightly secured.

**WARNING**

```

////////////////////////////////////
//
// When checking alignment, disconnect the power source to
// ensure that the pump will remain inoperative.
//
////////////////////////////////////

```

**CAUTION**

Adjusting the alignment in one direction may alter the alignment in another direction. Check each procedure after altering alignment.

**Coupled Drives**

When using couplings, the axis of the power source must be aligned to the axis of the pump shaft in both the horizontal and vertical planes. Most couplings require a specific gap or clearance between the driving and the driven shafts. Refer to the coupling manufacturer's service literature.

Align spider insert type couplings by using calipers to measure the dimensions on the circumference of the outer ends of the coupling hub every 90 degrees. The coupling is in alignment when the hub ends are the same distance apart at all points (see Figure 3a).

Align non-spider type couplings by using a feeler gauge or taper gauge between the coupling halves every 90 degrees. The coupling is in alignment when the hubs are the same distance apart at all points (see Figure 3b).

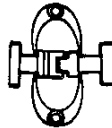

**Figure 3a. Aligning Spider-Type Couplings**



Figure 3b. Aligning Non-Spider Type Couplings

Check parallel adjustment by laying a straightedge across both coupling rims at the top, bottom, and side. When the straightedge rests evenly on both halves of the coupling, the coupling is in horizontal parallel alignment. If the coupling is misaligned, use a feeler gauge between the coupling and the straightedge to measure the amount of misalignment.

#### V-Belt Drives

When using V-belt drives, the power source and the pump must be parallel. Use a straightedge along the sides of the pulleys to ensure that the pulleys are properly aligned (see Figure 3c). In drive systems using two or more belts, make certain that the belts are a matched set; unmatched sets will cause accelerated belt wear.

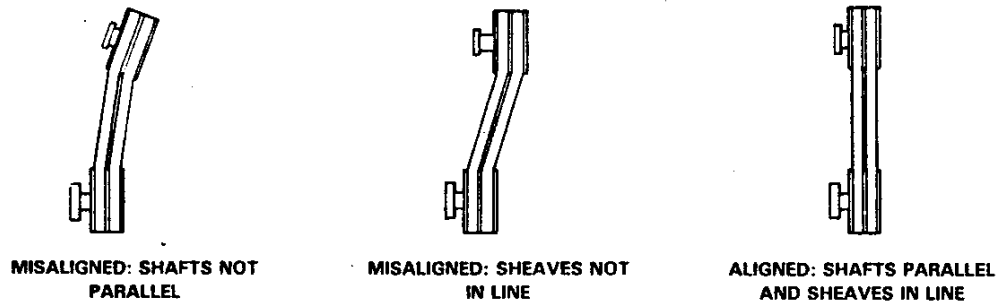

Figure 3c. Alignment of V-Belt Driven Pumps

Tighten the belts in accordance with the belt manufacturer's instructions. If the belts are too loose, they will slip; if the belts are too tight, there will be excessive power loss and possible bearing failure. Select pulleys that will match the proper speed ratio; overspeeding the pump may damage both pump and power source.



---

---

**WARNING**

```
////////////////////////////////////  
//  
// Do not operate the pump without shields and/or guards in //  
// place over rotating parts. Exposed rotating parts can //  
// catch clothing, fingers, or tools, causing severe injury //  
// to personnel. //  
//  
////////////////////////////////////
```

OPERATION - SECTION C

WARNING

```

////////////////////////////////////
//
// This pump is designed to pump liquids containing speci- //
// fied entrained solids. Do not attempt to pump volatile, //
// flammable or corrosive liquids which may damage the pump //
// or endanger personnel as a result of pump failure. //
//
////////////////////////////////////

```

CAUTION

Pump speed and operating condition points must be within the continuous performance range shown on the curve.

PRIMING

Install the pump and piping as described in INSTALLATION. Make sure that the piping connections are tight, and that the pump is securely mounted. Check that the pump is properly lubricated (see LUBRICATION in MAINTENANCE AND REPAIR).

This pump is self-priming, but the pump should never be operated unless there is liquid in the casing.

CAUTION

Never operate a self-priming pump unless there is liquid in the casing. The pump will not prime when dry. Extended operation of a dry pump will destroy the seal assembly.

Add liquid to the pump casing when:

1. The pump is being put into service for the first time.
2. The pump has not been used for a considerable length of time.
3. The liquid in the pump casing has evaporated.

Once the pump casing has been filled, the pump will prime and reprime as necessary.

**WARNING**

```

////////////////////////////////////
//
// After filling the pump casing, reinstall and tighten the //
// fill plug. Do not attempt to operate the pump unless //
// all connecting piping is securely installed. Otherwise, //
// liquid in the pump forced out under pressure could cause //
// injury to personnel. //
// //
////////////////////////////////////

```

To fill the pump, remove the pump casing fill cover or fill plug at the top of the casing and add clean liquid until the pump is filled. Replace the fill cover or fill plug before operating the pump.

**STARTING**

Consult the operations manual furnished with the power source.

**Rotation**

The correct direction of pump rotation is counterclockwise when facing the impeller. If the pump is operated in the wrong direction, the impeller could become loosened from the shaft and seriously damage the pump.

**CAUTION**

<p>Before starting the pump, check to make sure rotation is in the proper direction. Otherwise, the impeller could become loosened from the shaft and seriously damage the pump.</p>
--

Consult the operating manual furnished with the power source before attempting to start the power source.

If an electric motor is used to drive the pump, remove V-belts, couplings, or otherwise disconnect the pump from the motor before checking motor rotation. Operate the motor independently while observing the direction of the motor shaft, or cooling fan.

If rotation is incorrect on a three-phase motor, have a qualified electrician interchange any two of the three phase wires to change direction. If rotation is incorrect on a single-phase motor, consult the literature supplied with the motor for specific instructions.

---

---

## OPERATION

### Lines With a Bypass

Either a Gorman-Rupp automatic air release valve or a hand operated shutoff valve may be installed in a bypass line.

If a Gorman-Rupp automatic air release valve has been installed, close the throttling valve in the discharge line. The Gorman-Rupp valve will automatically open to allow the pump to prime, and automatically close when priming has been accomplished. After the pump has been primed, and liquid is flowing steadily from the bypass line, open the discharge throttling valve.

If a hand operated shutoff valve has been installed, close the throttling valve in the discharge line, and open the bypass shutoff valve so that the pump will not have to prime against the weight of the liquid in the discharge line. When the pump has been primed, and liquid is flowing steadily from the bypass line, close the bypass shutoff valve and open the discharge throttling valve.

### Lines Without a Bypass

Open all valves in the discharge line and start the power source. Priming is indicated by a positive reading on the discharge pressure gauge or by a quieter operation. The pump may not prime immediately because the suction line must first fill with liquid. If the pump fails to prime within five minutes, stop it and check the suction line for leaks.

After the pump has been primed, partially close the discharge line throttling valve in order to fill the line slowly and guard against excessive shock pressure which could damage pipe ends, gaskets, sprinkler heads, and any other fixtures connected to the line. When the discharge line is completely filled, adjust the throttling valve to the required flow rate.

### Leakage

No leakage should be visible at pump mating surfaces, or at pump connections or fittings. Keep all line connections and fittings tight to maintain maximum pump efficiency.

### Liquid Temperature And Overheating

The **maximum** liquid temperature for this pump is 160°F. Do not apply it at a higher operating temperature.

Overheating can occur if operated with the valves in the suction or discharge lines closed. Operating against closed valves could bring the liquid to a boil, build pressure, and cause the pump to rupture or explode. If overheating

OPERATION

occurs, stop the pump and allow it to cool before servicing it. Refill the pump casing with cool liquid.

WARNING

```

////////////////////////////////////
//
// Do not remove plates, covers, gauges, pipe plugs, or //
// fittings from an overheated pump. Vapor pressure within //
// the pump can cause parts being disengaged to be ejected //
// with great force. Allow the pump to cool before servic- //
// ing. //
// //
////////////////////////////////////

```

Strainer Check

If a suction strainer has been shipped with the pump or installed by the user, check the strainer regularly, and clean it as necessary. The strainer should also be checked if pump flow rate begins to drop. If a vacuum suction gauge has been installed, monitor and record the readings regularly to detect strainer blockage.

Pump Vacuum Check

Since this pump does not have a suction check valve, the discharge line must be fitted with a check valve if a pump vacuum reading is to be taken.

With the pump inoperative, install a vacuum gauge in the system, using pipe dope on the threads. Block the suction line and start the pump. At operating speed the pump should pull a vacuum of 20 inches or more of mercury. If it does not, check for air leaks in the seal, gasket, or discharge valve.

Open the suction line, and read the vacuum gauge with the pump primed and at operating speed. Shut off the pump. The vacuum gauge reading will immediately drop proportionate to static suction lift, and should then stabilize. If the vacuum reading falls off rapidly after stabilization, an air leak exists. Before checking for the source of the leak, check the point of installation of the vacuum gauge.

STOPPING

Never halt the flow of liquid suddenly. If the liquid being pumped is stopped abruptly, damaging shock waves can be transmitted to the pump and piping system. Close all connecting valves slowly. If the pump is driven by an engine, reduce the throttle speed slowly and allow the engine to idle briefly before stopping.

---

---

**CAUTION**

If application involves a high discharge head, gradually close the discharge throttling valve before stopping the pump.

After stopping the pump, disconnect or lock out the power supply to ensure that the pump will remain inoperative.

**Cold Weather Preservation**

In below freezing conditions, drain the pump to prevent damage from freezing. Also, clean out any solids by flushing with a hose. Operate the pump for approximately one minute; this will remove any remaining liquid that could freeze the pump rotating parts.

If the pump will be idle for more than a few hours, or if it has been pumping liquids containing a large amount of solids, drain the pump, and flush it thoroughly with clean water. To prevent large solids from clogging the drain port and preventing the pump from completely draining, insert a rod or stiff wire in the drain port, and agitate the liquid during the draining process. Clean out any remaining solids by flushing with a hose.

**BEARING TEMPERATURE CHECK**

Bearings normally run at higher than ambient temperatures because of heat generated by friction. Temperatures up to 160°F are considered normal for bearings, and they can operate safely to at least 180°F.

Checking bearing temperatures by hand is inaccurate. Bearing temperatures can be measured accurately by placing a contact-type thermometer against the housing. Record this temperature for future reference.

A sudden increase in bearing temperatures is a warning that the bearings are at the point of failing to operate properly. Make certain that the bearing lubricant is of the proper viscosity and at the correct level (see LUBRICATION in MAINTENANCE AND REPAIR). Bearing overheating can also be caused by shaft misalignment and/or excessive vibration.

When pumps are first started, the bearings may seem to run at temperatures above normal. Continued operation should bring the temperatures down to normal levels.



PUMP TROUBLESHOOTING - SECTION D

WARNING

```

////////////////////////////////////
//
// Before attempting to open or service the pump:
//
// 1. Familiarize yourself with this manual.
// 2. Disconnect or lock out the power supply to ensure
//    that the pump will remain inoperative.
// 3. Allow the pump to cool if overheated.
// 4. Vent the pump slowly and cautiously.
// 5. Close the suction and discharge valves.
// 6. Check the temperature before opening any covers,
//    plates, or plugs.
// 7. Drain the pump.
//
////////////////////////////////////
    
```

TROUBLE	POSSIBLE CAUSE	PROBABLE REMEDY
PUMP FAILS TO PRIME	Air leak in suction line. Lining of suction hose collapsed. Leaking or worn seal or pump gasket. Suction lift or discharge head too high.	Correct leak. Replace suction hose. Check pump vacuum. Replace leaking or worn seal or gasket. Check piping installation and install bypass line if needed. See INSTALLATION.
PUMP STOPS OR FAILS TO DELIVER RATED FLOW OR PRESSURE	Air leak in suction line. Suction intake not submerged at proper level or sump too small. Impeller or other wearing parts worn or damaged. Impeller clogged.	Correct leak. Check installation and correct as needed. Check submergence chart (Section B). Replace worn or damaged parts. Check that impeller is properly centered and rotates freely. Free impeller of debris.



TROUBLE	POSSIBLE CAUSE	PROBABLE REMEDY
PUMP STOPS OR FAILS TO DELIVER RATED FLOW OR PRES-SURE (cont.)	<p>Pump speed too slow.</p> <p>Discharge head too high.</p> <p>Suction lift too high.</p> <p>Leaking or worn seal or pump gasket.</p>	<p>Check driver output; check belts or couplings for slippage.</p> <p>Install bypass line.</p> <p>Measure lift w/vacuum gauge. Reduce lift and/or friction losses in suction line.</p> <p>Check pump vacuum. Replace leaking or worn seal or gasket.</p>
PUMP REQUIRES TOO MUCH POWER	<p>Pump speed too high.</p> <p>Discharge head too low.</p> <p>Liquid solution too thick.</p>	<p>Check driver output; check that sheaves or couplings are correctly sized.</p> <p>Adjust discharge valve.</p> <p>Dilute if possible.</p>
PUMP CLOGS FREQUENTLY	<p>Discharge flow too slow.</p> <p>Suction check valve or foot valve clogged or binding.</p>	<p>Open discharge valve fully to increase flow rate, and run power source at maximum governed speed.</p> <p>Clean valve.</p>
EXCESSIVE NOISE	<p>Cavitation in pump.</p> <p>Pumping entrained air.</p> <p>Pump or drive not securely mounted.</p> <p>Impeller clogged or damaged.</p> <p>Suction and discharge lines not properly supported.</p>	<p>Reduce suction lift and/or friction losses in suction line. Record vacuum and pressure gauge readings and consult local representative or factory.</p> <p>Locate and eliminate source of air bubble.</p> <p>Secure mounting hardware.</p> <p>Clean out debris; replace damaged parts.</p> <p>Check piping installation for proper support.</p>

TROUBLE	POSSIBLE CAUSE	PROBABLE REMEDY
BEARINGS RUN TOO HOT	<p>Bearing temperature is high, but within limits.</p> <p>Low or incorrect lubricant.</p> <p>Pump speed too high.</p> <p>Bearing(s) frozen.</p>	<p>Check bearing temperature regularly to monitor any increase.</p> <p>Check for proper type and level of lubricant.</p> <p>Reduce speed of power source.</p> <p>Disassemble pump and check bearing(s).</p>



PUMP MAINTENANCE AND REPAIR - SECTION E

MAINTENANCE AND REPAIR OF THE WEARING PARTS OF THE PUMP WILL MAINTAIN PEAK OPERATING PERFORMANCE.

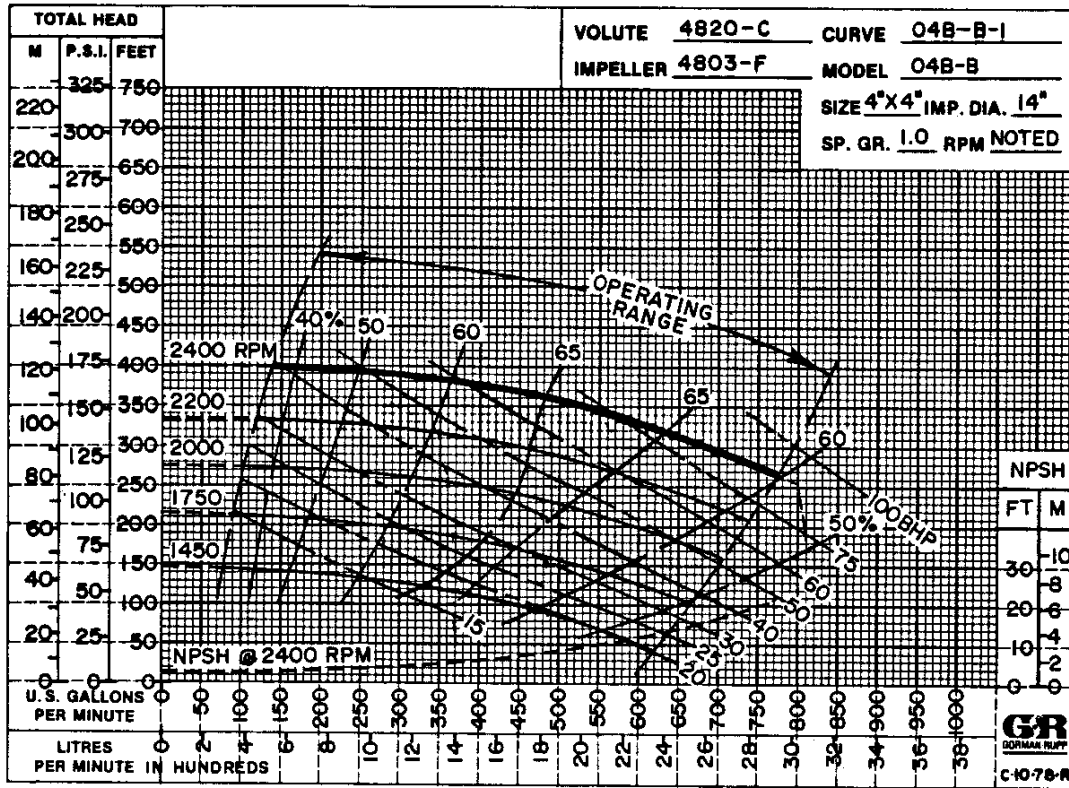

\*STANDARD PERFORMANCE FOR PUMP MODEL 04B52-B

\*Based on 70°F clear water at sea level with minimum suction lift. Since pump installations are seldom identical, your performance may be different due to such factors as viscosity, specific gravity, elevation, temperature, and impeller trim.

If your pump serial number is followed by an "N", your pump is NOT a standard production model. Contact the Gorman-Rupp Company to verify performance or part numbers.

CAUTION

Pump speed and operating condition points must be within the continuous performance range shown on the curve.

SECTIONAL DRAWING

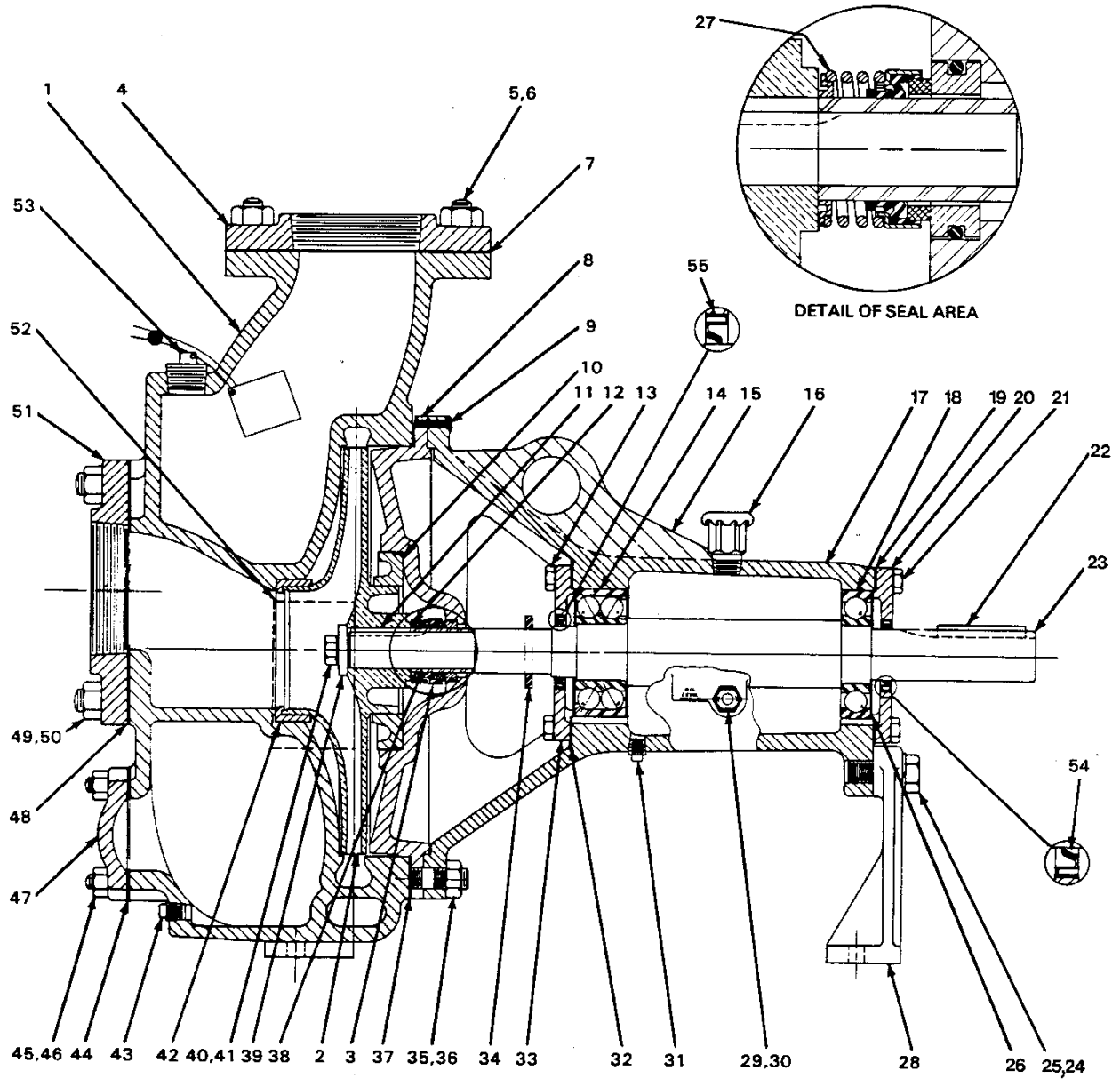

Figure 1. Pump Model 04B52-B

**PARTS LIST**  
**Pump Model 04B52-B**  
 (From S/N 806819 up)

If your pump serial number is followed by an "N", your pump is NOT a standard production model. Contact the Gorman-Rupp Company to verify part numbers.

ITEM NO.	PART NAME	PART NUMBER	MATL CODE	QTY	ITEM NO.	PART NAME	PART NUMBER	MATL CODE	QTY
1	PUMP CASING	4820-C	10010	1	30	PIPE PLUG	P00006	11990	1
2	*IMPELLER	4803-D	10010	1	31	PED DRAIN PLUG	P00006	11990	1
3	*SEAL ASSEMBLY	25284-961	-----	1	32	*BEARING CAP GSKT	5413-G	18000	1
4	DISCHARGE FLANGE	1756	10010	1	33	BEARING CAP	5413-A	10010	1
5	STUD	C01010	15991	8	34	DEFLECTOR RING	2352	19120	1
6	HEX NUT	D00010	15991	8	35	STUD	C01010	15991	12
7	*DISCH FLANGE GSKT	1676-GB	10010	1	36	HEX NUT	D00010	15991	12
8	SEAL PLATE	5792	10010	1	37	*PUMP CASING GSKT	4820-G	20000	1
9	RD HD MACH SCREW	X00404	17000	2	38	SHAFT SLEEVE	5827	17030	1
10	*WEAR RING	6902	10010	1	39	IMPELLER WASHER	5718	15990	1
11	*IMPELLER KEY	N00407	15990	1	40	IMP LOCKWASHER	AK00010	15991	1
12	*IMPELLER SHIM SET	37-J	17090	1	41	IMPELLER CAPSCREW	B01005-S	15991	1
13	HEX HD CAPSCREW	B00604	15991	4	42	*WEAR RING	3765-A	10010	1
14	*BALL BEARING	23421-461	-----	1	43	CASING DRAIN PLUG	P00006	11990	1
15	PEDESTAL	5402-A	10010	1	44	*COVER PLATE GSKT	4822-G	20000	1
16	LUB AIR VENT	S01703	-----	1	45	STUD	C00807	15991	6
17	ROTATION DECAL	2613-CU	-----	1	46	HEX NUT	D00008	15991	6
18	BALL BEARING	S01077	-----	1	47	COVER PLATE	4822	10010	1
19	*BEARING CAP GSKT	5413-G	18000	1	48	*SUCT FLANGE GSKT	1676-GB	20000	1
20	BEARING CAP	5413-A	10010	1	49	STUD	C01010	15991	8
21	HEX HD CAPSCREW	B00604	15991	4	50	HEX NUT	D00010	15991	8
22	SHAFT KEY	N00612	15990	1	51	SUCTION FLANGE	1756	10010	1
23	*IMPELLER SHAFT	5789	16040	1	52	NAME PLATE	2613-C	13990	1
24	HEX HD CAPSCREW	B01208	15991	1	53	FILL PLUG ASSY	48271-064	-----	1
25	LOCKWASHER	J00012	15991	1	54	*OIL SEAL	S01262	-----	1
26	*BEARING SHIM SET	8546	15990	1	55	*OIL SEAL	S01262	-----	1
27	SPRING HOLDER	25273-266	-----	1	NOT SHOWN:				
28	PEDESTAL FOOT	5801	10010	1		DRIVE SCREW	BM#04-03	-----	4
29	OIL LEVEL SIGHT GAUGE	26714-011	-----	1					

\*INDICATES PARTS RECOMMENDED FOR STOCK

Above Serial Numbers Do Not Apply To Pumps Made In Canada.

CANADIAN SERIAL NO ..... AND UP

PUMP AND SEAL DISASSEMBLY AND REASSEMBLY

This pump requires little service due to its rugged, minimum-maintenance design. However, if it becomes necessary to inspect or replace the wearing parts, follow these instructions which are keyed to the sectional view (see Figure 1) and the accompanying parts list.

Before attempting to service the pump, disconnect or lock out the power source to ensure that it will remain inoperative and close all connecting valves in the suction and discharge lines.

WARNING

```

////////////////////////////////////
//
// Before attempting to open or service the pump:
//
// 1. Familiarize yourself with this manual.
// 2. Disconnect or lock out the power supply to ensure
//    that the pump will remain inoperative.
// 3. Allow the pump to cool if overheated.
// 4. Vent the pump slowly and cautiously.
// 5. Close the suction and discharge valves.
// 6. Check the temperature before opening any covers,
//    plates, or plugs.
// 7. Drain the pump.
//
////////////////////////////////////

```

Pump Disassembly

Before attempting to service the pump, remove the suction and discharge piping.

Remove the pump casing drain plug (43) and drain the pump. Clean and reinstall the drain plug.

To service the wear rings, impeller, seal assembly, or seal plate, the pump casing must be removed from the base and pedestal. Remove the hardware securing the casing to the base. Remove the nuts (36), and separate the pump casing and gasket (37) from the seal plate (8) and pedestal (15). Inspect the gasket for wear or damage and replace as required.

WARNING

```

////////////////////////////////////
//
// Use lifting and moving equipment in good repair and with
// adequate capacity to prevent injuries to personnel or
// damage to equipment.
//
////////////////////////////////////

```

Inspect the wear ring (42), and replace if badly scored or worn. The wear ring is secured by a press fit.

---

---

### Impeller Removal

Remove the impeller capscrew and washers (39, 40 and 41). Install three 3/8 - 16 UNC capscrews (not supplied) into the impeller hub and use a gear puller to slide the impeller off the shaft. Use caution not to damage the impeller.

Disengage the impeller key (11) and remove the impeller adjusting shims (12). For ease of reassembly, tag and tie the shims or measure and record their thickness.

Inspect the wear ring (10) and remove it if badly worn or damaged. The wear ring is secured by a press fit.

### Seal Disassembly

Carefully remove the spring holder, spring, retainer, rotating element, stationary seal and seat, and the shaft sleeve (38). Use a stiff wire with a hooked end if necessary.

If no further disassembly is required, refer to **Seal Reassembly**.

### Shaft And Bearing Removal And Disassembly

When the pump is properly operated and maintained, the pedestal should not require disassembly. Disassemble the shaft and bearings **only** when there is evidence of wear or damage.

#### CAUTION

Shaft and bearing disassembly in the field is not recommended. These operations should be performed only in a properly-equipped shop by qualified personnel.

Remove the round head machine screws (9) and separate the seal plate (8) from the pedestal.

Remove the deflector ring (34) and key (22) from the shaft. Remove the hardware (13 and 21) and slide the bearing caps (20 and 33) off the shaft. Remove the bearing cap gaskets (19 and 32) and the bearing shim set (26). Tag and tie the shims or measure and record their thickness.

Inspect the lips on the oil seals (54 and 55) for damage and replace as necessary. The oil seals are retained in the bearing caps by a press fit.

Place a block of wood against the drive end of the shaft and tap the shaft and assembled bearings (14 and 18) out of the pedestal.

Use a bearing puller to remove the inboard bearing (14) and outboard bearing (18) from the shaft.



Shaft And Bearing Reassembly And Installation

Clean the bore of the pedestal, impeller shaft, and all component parts, (except bearings), with a cloth soaked in cleaning solvent. Inspect the parts for wear, and replace as necessary.

WARNING

```

////////////////////////////////////
//
// Most cleaning solvents are toxic and flammable. Use //
// them only in a well-ventilated area free from excessive //
// heat, sparks, and flame. Read and follow all prec- //
// autions printed on solvent containers. //
//
////////////////////////////////////

```

Inspect the shaft for distortion, nicks or scratches and for thread damage on the impeller end. Dress small nicks and burrs with a fine file or honing stone. Replace the impeller shaft if defective.

Clean the bearings thoroughly in **fresh** cleaning solvent. Dry the bearings with filtered air and coat with a light oil.

Rotate the bearings by hand to check for roughness or binding, and inspect the bearing balls. If rotation is rough or the balls are discolored, replace the bearings.

CAUTION

Bearings must be kept free of all dirt and foreign material. Failure to do so will greatly shorten bearing life. DO NOT spin dry bearings. This may scratch the balls or races and cause premature bearing failure.

The bearing tolerances provide a tight press fit onto the impeller shaft, and a snug slip fit into the pedestal. If the bearings slip on and off easily, the shaft is worn and must be replaced. The pedestal housing must be replaced if the bearings do not fit snugly.

Dip the bearings in clean oil and position them on the shaft. The loading groove on the inboard bearing **must** face toward the impeller. Use an arbor (or hydraulic) press to press the inboard bearing on until seated squarely against the shaft shoulder.

CAUTION

When installing the bearings onto the shaft, NEVER press or hit against the outer race, balls, or ball cage. Press **ONLY** on the inner race.

Press the outboard bearing on until seated squarely against the shaft shoulder.

Press the oil seals (54 and 55) into the bearing caps with the lips positioned as shown in Figure 1. Install the inboard bearing cap and gasket (32 and 33) and secure with the hardware (13).

Slide the shaft and assembled bearings into the pedestal until the inboard bearing seats against the bearing cap.

CAUTION

When installing the shaft and bearings into the bearing bore, push against the outer race. NEVER hit the balls or ball cage.

Install the same thickness of bearing shims (26) as previously removed and secure the outboard bearing cap and gasket (19 and 20) with the hardware (21).

NOTE

Impeller shaft end play should be .002 to .010 inch. Add or remove bearing shims to establish the correct endplay.

Lubricate the bearings as indicated in LUBRICATION.

Seal Installation

(Figures 1 and 2)

Install the deflector ring (34) on the shaft.

If the wear ring (10) was removed for replacement, press the wear ring into the seal plate until it seats squarely against the bore shoulder.

Position the seal plate over the shaft and secure it to the intermediate with the two round head machine screws (9).

Clean the seal cavity and shaft with a cloth soaked in fresh cleaning solvent.

WARNING

Most cleaning solvents are toxic and flammable. Use them only in a well-ventilated area free from excessive heat, sparks, and flame. Read and follow all precautions printed on solvent containers.

The seal is not normally reused because wear patterns on the finished faces cannot be realigned during reassembly. This could result in premature failure. If necessary to reuse an old seal in an emergency, carefully wash all metallic parts in fresh cleaning solvent and allow to dry thoroughly.

Handle the seal parts with extreme care to prevent damage. Be careful not to contaminate precision finished faces; even fingerprints on the faces can shorten seal life. If necessary, clean the faces with a non-oil based solvent and a clean lint free tissue. Wipe **lightly** in a concentric pattern to avoid scratching the faces.

Inspect the seal components for wear, scoring, grooves, and other damage that might cause leakage. Clean and polish the shaft sleeve, or replace it if there are nicks or cuts on either end. If any components are worn, replace the complete seal; **never mix old and new seal parts.**

If a replacement seal is being used, remove it from the container and inspect the precision finished faces to ensure that they are free of any foreign matter.

To ease installation of the seal, lubricate the O-rings and bellows with water or a very **small** amount of oil, and apply a drop of light lubricating oil on the finished faces. Assemble the seal as follows, (see Figure 2).

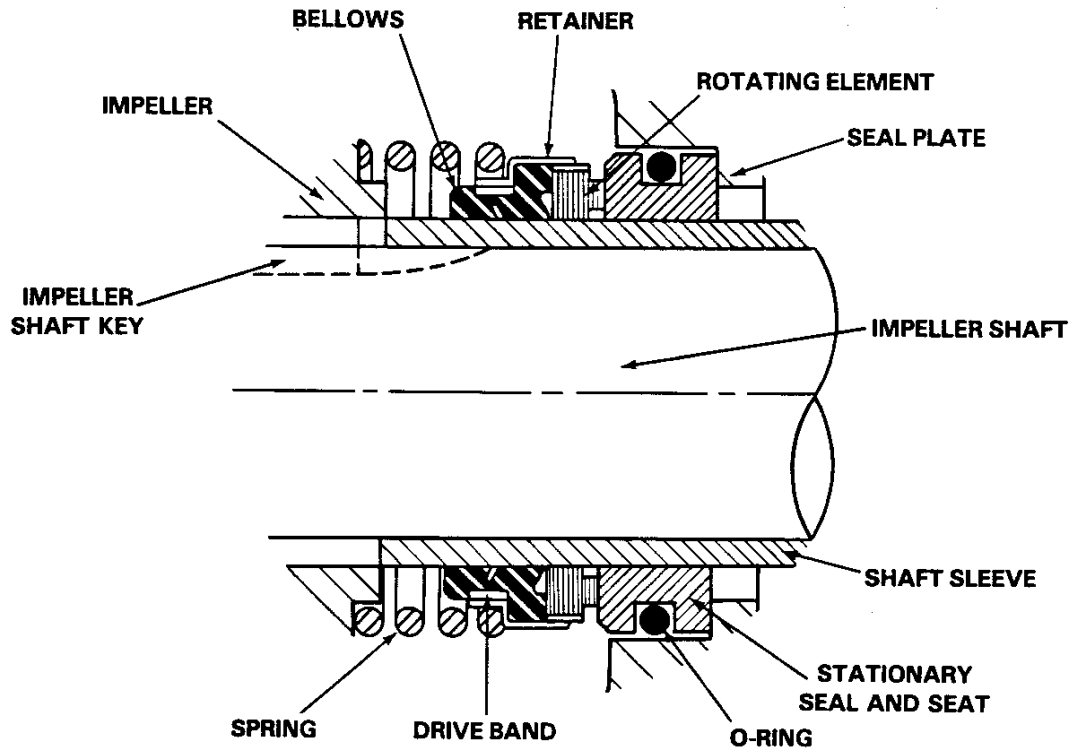

Figure 2. 25284-961 Seal Assembly

#### CAUTION

This seal is not designed for operation at temperatures above 160°F. Do not use at higher operating temperatures.

Install the stationary seat O-ring in the stationary seat. Press this assembly into the seal bore. Be careful not to damage the seal face.

Lubricate the shaft sleeve with water or light oil and subassemble the parts so that the rotating seal element is **just flush** with the **chamfered** end of the shaft.

Place the sleeve and subassembled seal on the shaft and push the sleeve through the seal until the chamfered end seats against the shaft shoulder.

### Pump Reassembly

Inspect the impeller, and replace it if cracked or badly worn.

Slide the same number of impeller adjusting shims (12) as previously removed onto the shaft. Install the key (11) and press the impeller on the shaft until fully seated.

For maximum pump efficiency, the impeller vanes must be centered within the volute scroll.

To verify the impeller positioning, measure the pump casing and impeller as shown in Figure 3. Use these measurements to calculate the required impeller location (dimension E). Add or remove impeller adjusting shims until dimension E is obtained.

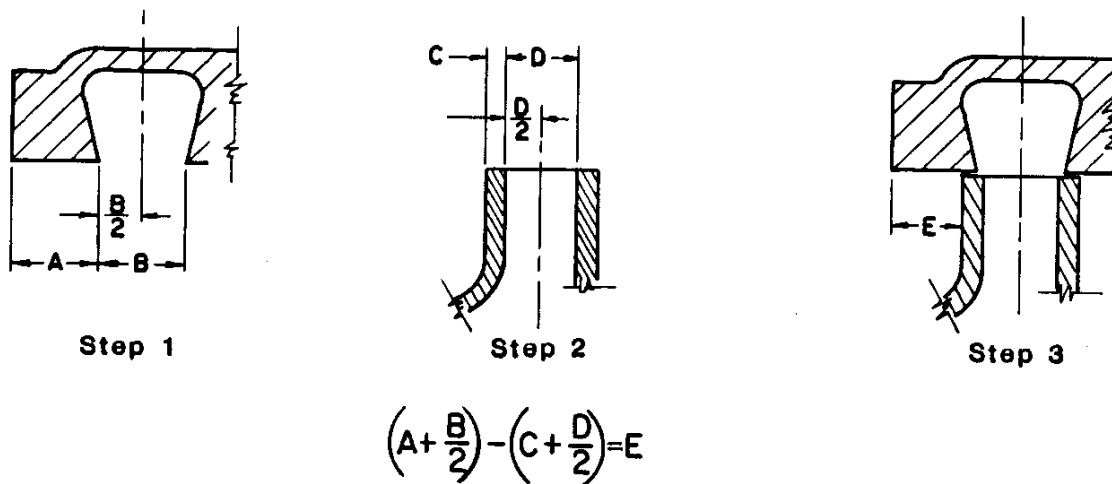

Figure 3. Centering Impeller Within Volute Scroll

#### NOTE

After the impeller has been properly positioned, check for free rotation. Correct any scraping binding before further reassembly.

Install the impeller capscrew and washers (39, 40 and 41).

---

---

If the wear ring (42) was removed for replacement, press the wear ring into the pump casing until it seats squarely against the bore shoulder.

Install the pump casing gasket (37) and secure the pump casing to the pedestal with the hardware (36).

Be sure to reinstall any leveling shims used under the pump casing mounting feet before installing the base mounting hardware.

#### Final Pump Reassembly

**Be sure** the pump is secure to the base and power source.

Install the suction and discharge lines and open all valves. Make certain that all piping connections are tight, properly supported and secure.

**Be sure** the pump and power source have been properly lubricated, see LUBRICATION.

Fill the pump casing with clean liquid. Reinstall the fill plug and tighten it.

Refer to **OPERATION**, Section C, before putting the pump back into service.

## LUBRICATION

### Seal Assembly

The seal assembly is lubricated by the liquid being pumped.

### Bearings

In normal service, drain and refill the bearing cavity with clean oil yearly. Check the oil level regularly, and when oil is required, remove the air vent (16) and fill the bearing cavity with SAE No. 30 non-detergent motor oil to the mid-point of the oil level sight gauge (29). Make sure the white reflector on the sight gauge is positioned horizontally to provide proper drainage. Clean and reinstall the air vent.

**For U.S. and International Warranty Information,  
Please Visit [www.grpumps.com/warranty](http://www.grpumps.com/warranty)**

**or call:**

**U.S.: 419-755-1280**

**International: +1-419-755-1352**

**For Canadian Warranty Information,  
Please Visit [www.grcanada.com/warranty](http://www.grcanada.com/warranty)**

**or call:**

**519-631-2870**

**THE GORMAN-RUPP COMPANY • MANSFIELD, OHIO**

**GORMAN-RUPP OF CANADA LIMITED • ST. THOMAS, ONTARIO, CANADA**