

**GHS SERIES  
 FLEXIBLE SEAL  
 HEAVY DUTY STANDARD  
 STAINLESS STEEL ROTARY  
 GEAR PUMP**

This heavy duty series with internal “wetted” parts of 316 Stainless Steel is ideal for handling corrosive applications. Superior rotor shaft support and an integral maintenance-free radial/thrust bearing, reduce deflection and wear. Due to the “galling” nature of stainless, extra internal clearance is necessary. A capacity correction table for liquids less than 750 SSU is available in Section 500.

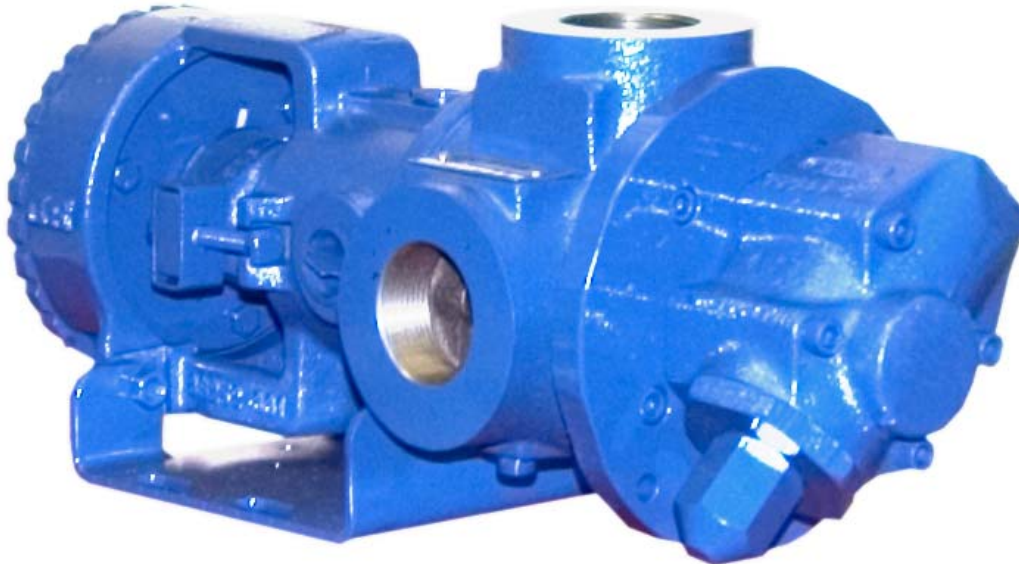

SHOWN <sup>W</sup>/INTERCHANGE FOOT BRACKET

The GHS stainless series is designed for applications in the operating ranges noted below. These units are available with head and backhead jackets for temperature control, silicon carbide bushings for wear resistance, and numerous shaft seal options described on the following pages.

**FEATURES**

- 200 PSI CAPABILITY
- BALL BEARING THRUST CONTROL
- ROTOR END CLEARANCE EXTERNALLY ADJUSTABLE
- EXCEPTIONAL SEAL VERSATILITY WITH INTERNAL SEAL VENT
- COMPUTER PROFILED GEARING FOR QUIET OPERATION
- MULTIPLE PORT POSITIONS
- FLEXIBLE SEAL DESIGN ALLOWS FOR A VARIETY OF INDUSTRY STANDARD SEALS OR PACKING

**OPERATING RANGE**

- CAPACITY (GPM): (3 TO 295)  
 [LPM] : [11 TO 1116]
- PRESSURE (PSI) : [0 TO 200]  
 [BAR] : [0 TO 14]
- VISCOSITY (SSU) : (28 TO 2,000,000)  
 [cSt] : [1 TO 440,000]
- TEMPERATURE (F) : (-30° TO 675°)  
 [C] : [-34° TO 358°]

**APPLICATIONS**

- USE WITH ANY CLEAN LIQUID COMPATIBLE WITH 316 STAINLESS STEEL
- ★ BOOSTER SERVICE
  - ★ CIRCULATING
  - ★ FILTERING
  - ★ LUBRICATING
  - ★ TRANSFERRING

EXTERIOR	BACKH.D	ROTOR & IDLER	HOUSING PORTS	BUSHING	IDLER PIN	SHAFT	SHAFT SEALING		ROTA-TION	INTERNAL RELIEF VALVE	
							MECH. SEAL	PACKING		MATERIAL	SETTING
316 STAIN. STEEL	CAST IRON	316 STAIN. STEEL	GHC 180° FLG. GHS 90° NPT	CARBON GRAPHITE	COATED 316 SST	STAIN. STEEL	CARBON, SIC, TEFLON ENC.	CARBON FIBER	C.W.	316 STAINLESS STEEL	75 PSI [5 BAR]

**G H C 1 DC 9 - B**  
**G H S 1 DC 9 - B**  
 | | | | | | | | | | | |  
 GEAR DUTY DESIGN PORT SIZE HYD. SIZE SEAL STYLE

## Standard Models

MODEL NUMBER		NOM. CAPACITY - SPEED				MAXIMUM				SHIPPING DATA	
		MAXIMUM		ALTERNATIVE		DIFF. PRESSURE - PSI [BAR]			TEMP.	Wt.	Vol.
		GPM [LPM]	RPM 60 Hz [50 HZ]	GPM [LPM]	RPM 60 Hz [50 HZ]	BELOW 38 SSU [4 cSt]	38 TO 100 SSU [21 cSt]	100 TO 250,000 SSU [55,000 cSt]	°F [°C]		
<b>GHC</b>	<b>GHS</b>										
<b>GHC 1 DC9-B</b> ① ● ▸	<b>GHS 1 DC9-B</b> ① ● ● <b>GHS 1 DC10-B</b> ① ● ■	9 [28]		6 [19]							32 [14,5] 2.9
<b>GHC 1 DE9-B</b> ① ● ● ▸	<b>GHS 1 DE9-B</b> ① ● ● ● <b>GHS 1 DE10-B</b> ① ● ■	11 [35]		7 [22]							32 [14,5] 2.9
<b>GHC 1-1/2 GC9-B</b> ● ● ▸	<b>GHS 1-1/2 GC9-B</b> ● ● ● <b>GHS 1-1/2 GC10-B</b> ■	16 [50]		10 [32]							63 [28,6] 2.9
	<b>GHS 2 GC9-B</b> ● ● ● <b>GHS 2 GC10-B</b> ■										63 [28,6] 2.9
<b>GHC 1-1/2 GF9-B</b> ● ● ▸	<b>GHS 1-1/2 GF9-B</b> ● ● ● ● <b>GHS 1-1/2 GF10-B</b> ■	23 [73]	1750 [1460]	15 [47]	1150 [960]						GHC ● 350 [177] 63 [28,6] 2.9
	<b>GHS 2 GF9-B</b> ● ● ● ● <b>GHS 2 GF10-B</b> ■										63 [28,6] 2.9
<b>GHC 1-1/2 GH9-B</b> ● ● ▸	<b>GHS 1-1/2 GH9-B</b> ● ● ● ● <b>GHS 1-1/2 GH10-B</b> ■	31 [98]		20 [63]		75 [5]	100 [7]	200 [14]			GHS ● 400 [204] 63 [28,6] 2.9
	<b>GHS 2 GH9-B</b> ● ● ● ● <b>GHS 2 GH10-B</b> ■										63 [28,6] 2.9
<b>GHC 1-1/2 GJ9-B</b> ● ● ▸	<b>GHS 1-1/2 GJ9-B</b> ● ● ● ● <b>GHS 1-1/2 GJ10-B</b> ■	38 [120]		25 [79]							GHS ■ 500 [260] 63 [28,6] 2.9
	<b>GHS 2 GJ9-B</b> ● ● ● ● <b>GHS 2 GJ10-B</b> ■										63 [28,6] 2.9
	<b>GHS 2 JG9-B</b> ● ● ● ● <b>GHS 2 JG10-B</b> ■	40 [126]	1150 [960]	30 [95]	870 [725]						161 [73,2] 5.3
<b>GHC 3 JG9-B</b> ● ● ▸	<b>GHS 3 JG9-B</b> ● ● ● ● <b>GHS 3 JG10-B</b> ■										161 [73,2] 5.3
	<b>GHS 2 JJ9-B</b> ● ● ● ● <b>GHS 2 JJ10-B</b> ■	56 [177]		42 [133]							161 [73,2] 5.3
<b>GHC 3 JJ9-B</b> ● ● ▸	<b>GHS 3 JJ9-B</b> ● ● ● ● <b>GHS 3 JJ10-B</b> ■										161 [73,2] 5.3

STANDARD MODELS CONTINUED

① 3450 [2875] RPM PERMISSIBLE TO 1,000 SSU [220 cSt.] AND 100 PSI [7 BAR]

● MECHANICAL SEAL  
■ PACKING/LIP SEAL

▸ PORTS ARE COMPATIBLE WITH 150# ANSI FLANGES. ALL OTHER PORTS ARE TAPPED NPT FOR ANSI PIPE. OPTIONAL [DIN] FLANGES OR TAPPED [BSP] PORTS ARE AVAILABLE FOR EXPORT MARKET.

NOTE: RECOMMENDED PORT SIZES ARE SHOWN IN **BOLDFACE**. EXAMPLE: **GHC 1 DC9-B, GHS 1 DC9-B**

**THE GORMAN-RUPP COMPANY • MANSFIELD, OHIO**

GORMAN-RUPP OF CANADA LIMITED • ST. THOMAS, ONTARIO, CANADA

# Standard Models (Continued)

MODEL NUMBER		NOM. CAPACITY - SPEED				MAXIMUM				SHIPPING DATA	
		MAXIMUM		ALTERNATIVE		DIFF. PRESSURE - PSI [BAR]			TEMP.	Wt.	Vol.
		GPM [LPM]	RPM 60 Hz [50 HZ]	GPM [LPM]	RPM 60 Hz [50 HZ]	BELOW 38 SSU [4 cSt]	38 TO 100 SSU [21 cSt]	100 TO 250,000 SSU [55,000 cSt]	°F [°C]	LBS [KG]	CU. FT.
GHC	GHS 2 JL9-B ●	77 [243]	1150 [960]	58 [133]	870 [725]	75 [5]	100 [7]	200 [14]	161 [73,2]	5.3	
	GHS 2 JL10-B ■										
GHC 3 JL9-B ● †	GHS 3 JL9-B ●	107 [338]	960 [960]	81 [256]	580 [480]	75 [5]	100 [7]	200 [14]	161 [73,2]	5.3	
	GHS 3 JL10-B ■										
GHC	GHS 2 JP9-B ●	107 [338]	960 [960]	81 [256]	580 [480]	75 [5]	100 [7]	200 [14]	161 [73,2]	5.3	
	GHS 2 JP10-B ■										
GHC 3 JP9-B ● †	GHS 3 JP9-B ●	132 [500]	960 [960]	80 [252]	580 [480]	75 [5]	100 [7]	200 [14]	161 [73,2]	5.3	
	GHS 3 JP10-B ■										
GHC	GHS 2 NK9-B ●	99 [375]	960 [960]	60 [189]	580 [480]	75 [5]	100 [7]	200 [14]	180 [81,8]	5.3	
	GHS 2 NK10-B ■										
GHC	GHS 2-1/2 NK9-B ●	132 [500]	960 [960]	80 [252]	580 [480]	75 [5]	100 [7]	200 [14]	180 [81,8]	5.3	
	GHS 2-1/2 NK10-B ■										
GHC	GHS 3 NK9-B ●	165 [624]	960 [960]	99 [312]	580 [480]	75 [5]	100 [7]	200 [14]	180 [81,8]	5.3	
	GHS 3 NK10-B ■										
GHC	GHS 2 NM9-B ●	165 [624]	960 [960]	99 [312]	580 [480]	75 [5]	100 [7]	200 [14]	180 [81,8]	5.3	
	GHS 2 NM10-B ■										
GHC	GHS 2-1/2 NM9-B ●	172 [542]	960 [960]	115 [362]	580 [480]	75 [5]	100 [7]	200 [14]	180 [81,8]	5.3	
	GHS 2-1/2 NM10-B ■										
GHC	GHS 3 NM9-B ●	215 [678]	960 [960]	143 [451]	480 [400]	75 [5]	100 [7]	200 [14]	180 [81,8]	5.3	
	GHS 3 NM10-B ■										
GHC	GHS 2-1/2 NP9-B ●	215 [678]	960 [960]	143 [451]	480 [400]	75 [5]	100 [7]	200 [14]	180 [81,8]	5.3	
	GHS 2-1/2 NP10-B ■										
GHC	GHS 3 NP9-B ●	215 [678]	960 [960]	143 [451]	480 [400]	75 [5]	100 [7]	200 [14]	180 [81,8]	5.3	
	GHS 3 NP10-B ■										
GHC	GHS 2 RM9-B ●	172 [542]	960 [960]	115 [362]	580 [480]	75 [5]	100 [7]	200 [14]	357 [162]	10.7	
	GHS 2 RM10-B ■										
GHC	GHS 2-1/2 RM9-B ● †	215 [678]	960 [960]	143 [451]	480 [400]	75 [5]	100 [7]	200 [14]	357 [162]	10.7	
	GHS 2-1/2 RM10-B ■ †										
GHC	GHS 3 RM9-B ● †	215 [678]	960 [960]	143 [451]	480 [400]	75 [5]	100 [7]	200 [14]	357 [162]	10.7	
	GHS 3 RM10-B ■ †										
GHC	GHS 4 RM9-B ● †	215 [678]	960 [960]	143 [451]	480 [400]	75 [5]	100 [7]	200 [14]	357 [162]	10.7	
	GHS 4 RM10-B ■ †										
GHC	GHS 3 RP9-B ● †	215 [678]	960 [960]	143 [451]	480 [400]	75 [5]	100 [7]	200 [14]	357 [162]	10.7	
	GHS 3 RP10-B ■ †										
GHC	GHS 4 RP9-B ● †	215 [678]	960 [960]	143 [451]	480 [400]	75 [5]	100 [7]	200 [14]	357 [162]	10.7	
	GHS 4 RP10-B ■ †										

STANDARD MODELS CONTINUED

- MECHANICAL SEAL
- PACKING/LIP SEAL

† PORTS ARE COMPATIBLE WITH 150# ANSI FLANGES. ALL OTHER PORTS ARE TAPPED NPT FOR ANSI PIPE. OPTIONAL [DIN] FLANGES OR TAPPED [BSP] PORTS ARE AVAILABLE FOR EXPORT MARKET.

NOTE: RECOMMENDED PORT SIZES ARE SHOWN IN **BOLDFACE**. EXAMPLE: **GHC 1 DC9-B, GHS 1 DC9-B**

**THE GORMAN-RUPP COMPANY • MANSFIELD, OHIO**  
 GORMAN-RUPP OF CANADA LIMITED • ST. THOMAS, ONTARIO, CANADA

MODEL NUMBER		NOM. CAPACITY - SPEED				MAXIMUM				SHIPPING DATA	
		MAXIMUM		ALTERNATIVE		DIFF. PRESSURE - PSI [BAR]			TEMP.	Wt.	Vol.
		GPM [LPM]	RPM 60 Hz [50 HZ]	GPM [LPM]	RPM 60 Hz [50 HZ]	BELOW 38 SSU [4 cSt]	38 TO 100 SSU [21 cSt]	100 TO 250,000 SSU [55,000 cSt]	°F [°C]	LBS [KG]	CU. FT.
GHC	GHS										
	GHS 3 RR9-B ● ▸ GHS 3 RR10-B ■ ▸	255 [804]	720 [600]	170 [536]	480 [400]	75 [5]	100 [7]	200 [14]	GHS ● 400 [204] ■ 500 [260]	357 [162]	10.7
	GHS 4 RR9-B ● ▸ GHS 4 RR10-B ■ ▸			196 [618]						357 [162]	
	GHS 4 RS9-B ● ▸ GHS 4 RS10-B ■ ▸			295 [930]						357 [162]	

▸ PORTS ARE COMPATIBLE WITH 150# ANSI STAINLESS STEEL FLANGES. ALL OTHER PORTS ARE TAPPED NPT FOR ANSI PIPE. OPTIONAL [DIN] FLANGES OR TAPPED [BSP] PORTS AVAILABLE FOR EXPORT MARKET.

NOTE: RECOMMENDED PORT SIZES ARE SHOWN IN BOLDFACE. EXAMPLE: **GHC 1 DC9-B**, **GHS 1 DC9-B**

APPLICATION RECOMMENDATIONS:		
APPLICATION	OPTIONS REQUIRED (Select One From Each Row)	OPERATING LIMITATIONS
GHS ONLY HIGH TEMPERATURE	25U, 25V, OR 25W 35J – 35M (AS REQ'D) 40R, 70K 61H OR 65Q	TEMPERATURE: 675 °F MAX. PRESSURE: 200 PSI MAX.
GHS ONLY JACKETED	40K, 40W, 41U, 41W	LIMIT JACKET PRESSURE TO 150 PSI

NOTE: PROPER PUMP APPLICATION REQUIRES CONSIDERATION OF ADDITIONAL FACTORS. PLEASE REVIEW APPLICATION GUIDE IN SECTION 500 OR CONSULT THE FACTORY.

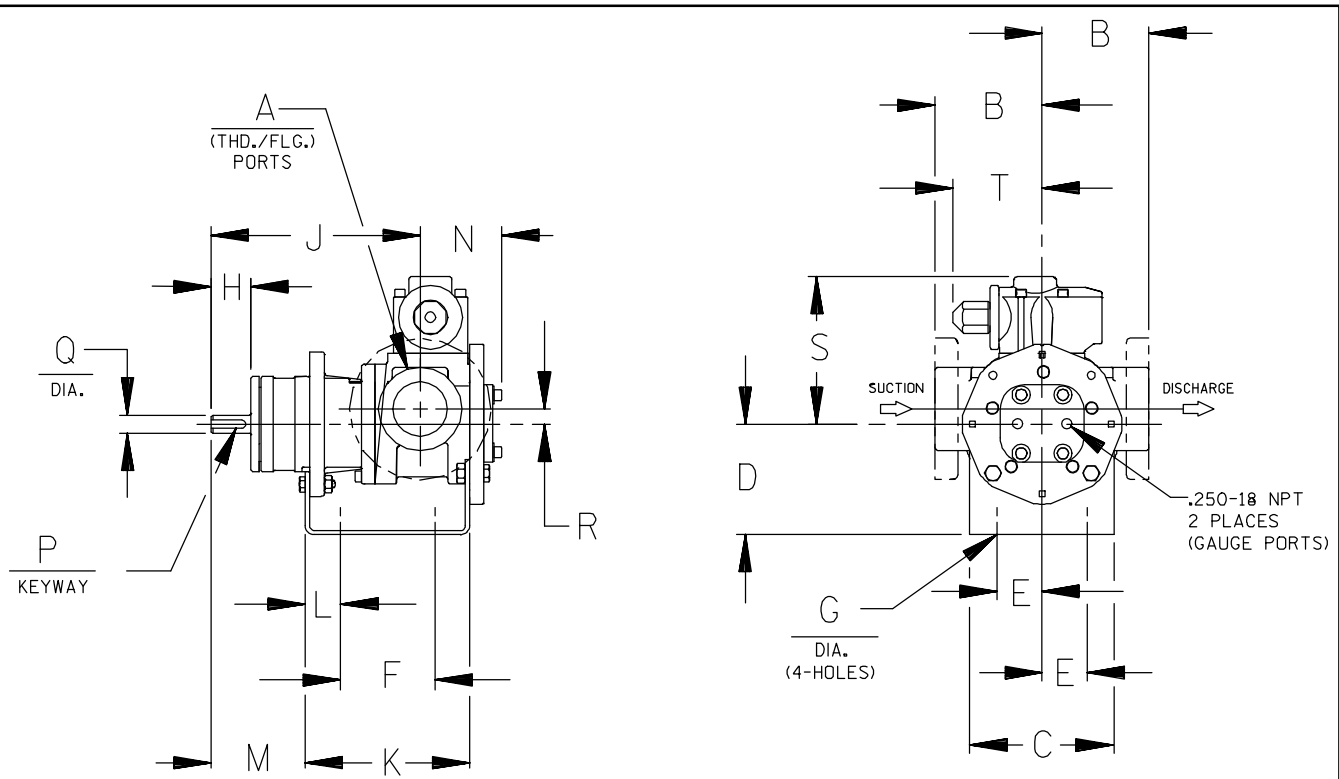

CAD FILE NO.: 16458B

MODEL NUMBERS	PUMP DIMENSIONS - INCHES [MILLIMETERS]																	
	A	B	C	D	E	F	G	H	J	K	L	M	N	P	Q	R	S	T
GHC D	1"	2.50 [64] †	4.00 [102]	3.50* [89]	1.62 [41]	3.12 [79]	.41 [10]	1.16 [30]	6.19 [157]	5.04 [128]	.76 [19]	2.62 [66]	2.74 [70]	.12 [3]	.50 [13]	.62 [16]	5.19 [132]	3.58 [91]
		4.00* [102] †		5.25 [133]										.75 [19]				
GHC G	1-1/2"	3.50 [89] †	5.88 [149]	3.50* [89]	1.62 [41]	4.00 [102]	.41 [10]	1.62 [41]	8.50 [216]	6.71 [170]	1.06 [27]	3.82 [97]	3.35 [85]	.19 [5]	.75 [19]	.62 [16]	6.00 [152]	3.62 [92]
		4.00* [102] †		4.50 [114]										5.25 [133]				
GHC J	3"	4.50 [114] †	6.88 [175]	4.50 [114]	2.88 [73]	4.25 [108]	.44 [11]	2.50 [64]	12.12 [308]	9.75 [248]	1.75 [44]	5.50 [140]	4.66 [118]	.25 [6]	1.00 [25]	1.12 [28]	9.06 [230]	6.75 [171]
		6.00* [152] †		5.25* [133]										6.25 [159]				

\* STANDARD DIMENSION

† PORTS ARE COMPATIBLE WITH 125\* OR 250\* ANSI CAST IRON FLANGES. ALL OTHER PORTS ARE TAPPED NPT FOR ANSI PIPE. OPTIONAL (DIN) FLANGES OR TAPPED (BSP) PORTS AVAILABLE FOR EXPORT MARKET.

† 90° HOUSING

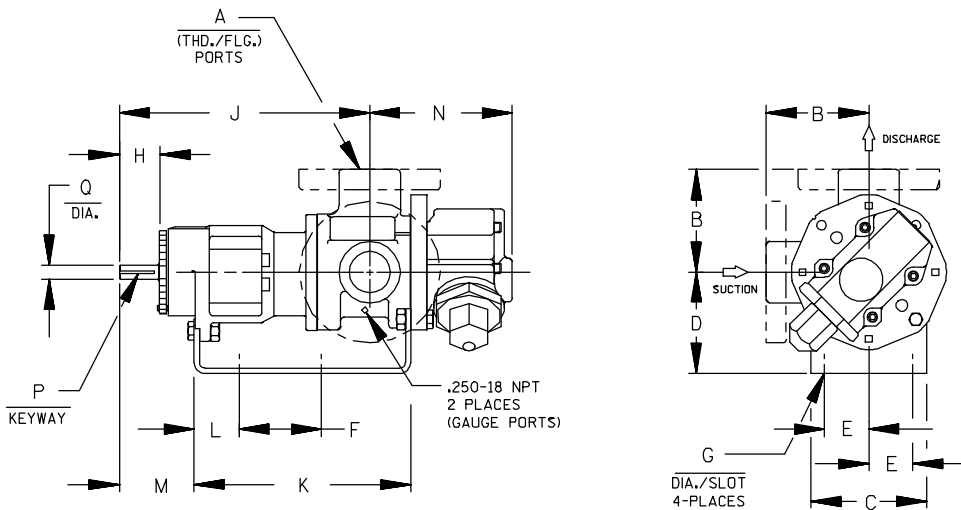

CAD FILE NO.: 16669G

MODEL NUMBERS	PUMP DIMENSIONS - INCHES [MILLIMETERS]														
	A	B	C	D	E	F	G	H	J	K	L	M	N	P	Q
GHS D	1"	2.50* [641]	4.00 [102]	3.50* [891]	1.62 [41]	5.50 [140]	.41 [10]	1.16 [30]	8.43 [214]	7.54 [192]	1.09 [28]	2.29 [58]	4.98 [127]	.12 [3] x .75 [19]	.50 [13]
		4.00 † [102]		5.25 [133]											
GHS G	1-1/2"  2"	3.50* [891]	4.88 [124]	3.50* [891]	1.62 [41]	8.00 [203]	.41 [10]	1.62 [41]	12.06 [306]	10.72 [272]	1.52 [39]	3.35 [85]	5.70 [145]	.19 [5] x 1.25 [32]	.75 [19]
		4.00 † [102]		5.25 [133]											
GHS J	2"  3"	4.50* [114]	6.88 [175]	5.25* [133]	2.88 [73]	10.00 [254]	.44 [11]	2.50 [64]	15.68 [398]	14.31 [363]	2.77 [70]	4.48 [114]	8.50 [216]	.25 [6] x 2.00 [51]	1.00 [25]
		6.00 † [152]		6.25 [159]											
GHS N	2"  3"	5.12 [130]	8.00 [203]	4.50 [114]	2.88 [73]	10.00 [254]	.44 [11]	2.58 [66]	16.37 [416]	15.14 [385]	2.69 [68]	4.56 [116]	8.72 [221]	.25 [6] x 2.00 [51]	1.12 [28]
				5.25* [133]											
GHS R	2"	6.50 [165]	10.50 [267]	7.00 [178]	3.75 [95]	13.75 [349]	.52 [13]	2.25 [57]	17.87 [454]	17.36 [441]	1.86 [47]	4.70 [119]	11.31 [287]	.38 [10] x 1.88 [48]	1.44 [37]
	2-1/2"														
	3"														
	4"	7.19 † [183]													

\* STANDARD DIMENSION

† PORTS ARE COMPATIBLE WITH 150# OR 300# ANSISTAINLESS STEEL FLANGES. ALL OTHER PORTS ARE TAPPED NPT FOR ANSI PIPE. OPTIONAL (DIN) FLANGES OR TAPPED (BSP) PORTS AVAILABLE FOR EXPORT MARKET.

‡ 180° HOUSING

# **GHC/GHS**

**FOR GHC DRIVE OPTIONS**

**AND DIMENSIONS**

**SEE SECTION 540**

**FOR GHS DRIVE OPTIONS**

**AND DIMENSIONS**

**SEE SECTION 545**



# PERFORMANCE CURVES

## SPEED VS. CAPACITY/HORSEPOWER

**GF** Hydraulic Size

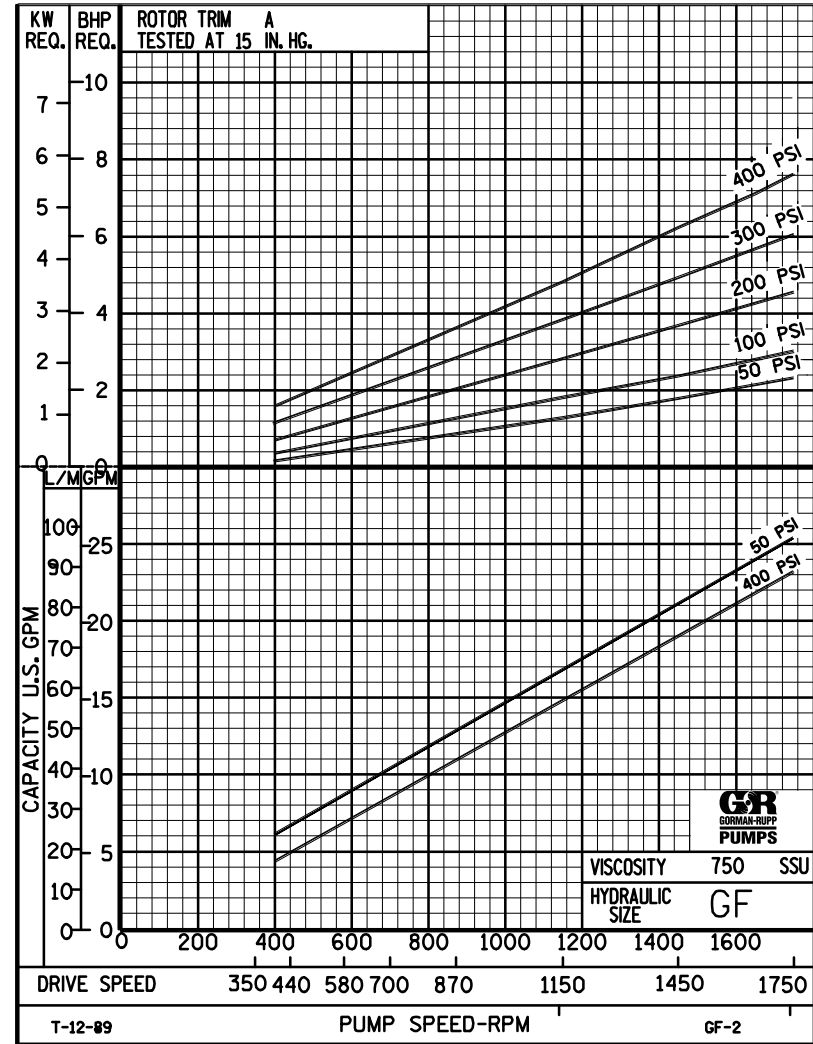
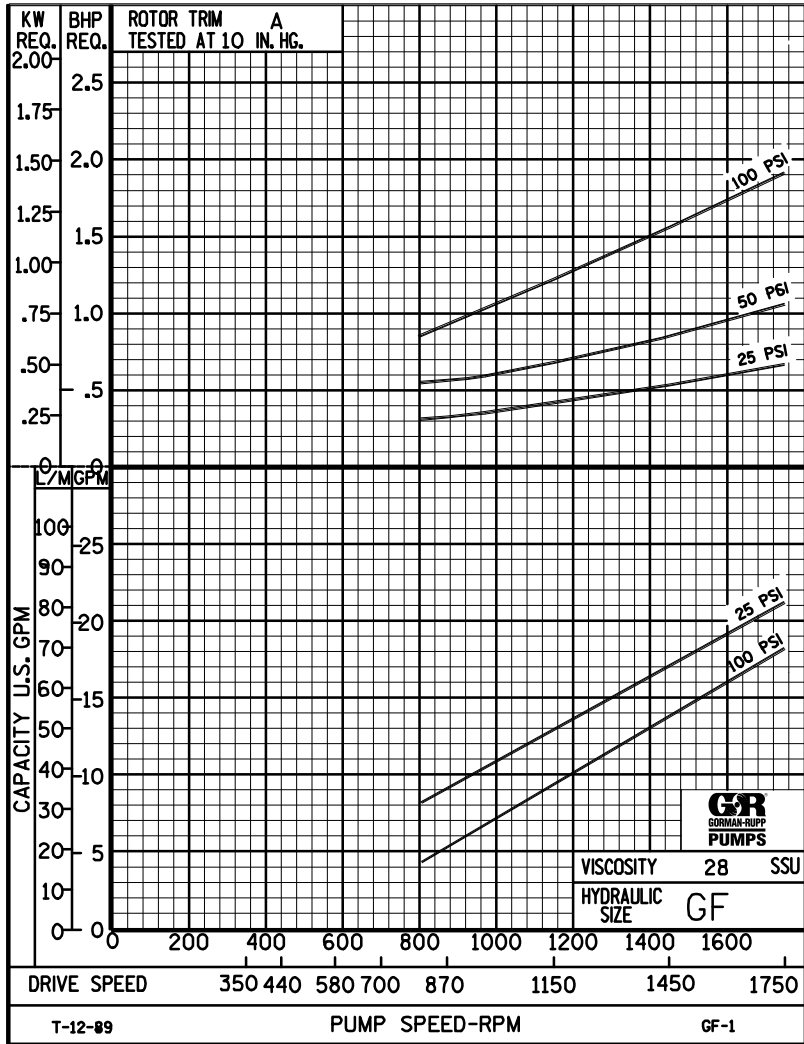

THE GORMAN-RUPP COMPANY • MANSFIELD, OHIO  
 GORMAN-RUPP OF CANADA LIMITED • ST. THOMAS, ONTARIO, CANADA

Printed in U.S.A.





# PERFORMANCE CURVES

## SPEED VS. CAPACITY/HORSEPOWER

**GF** Hydraulic Size

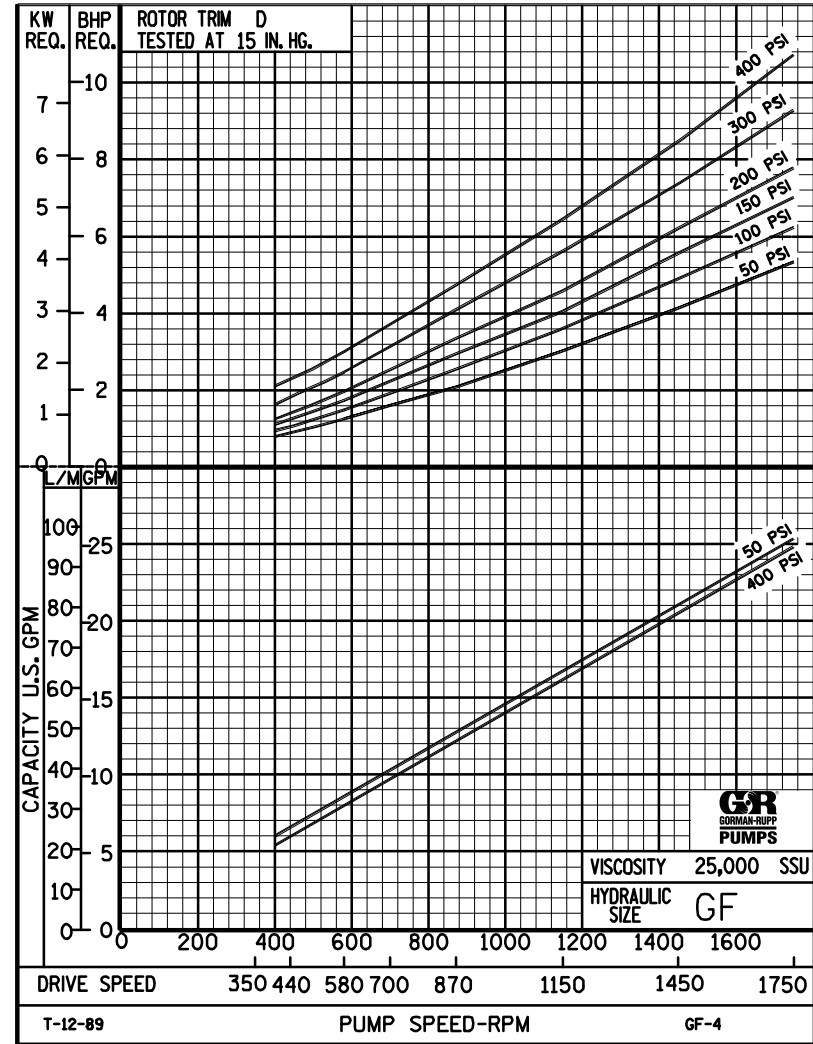
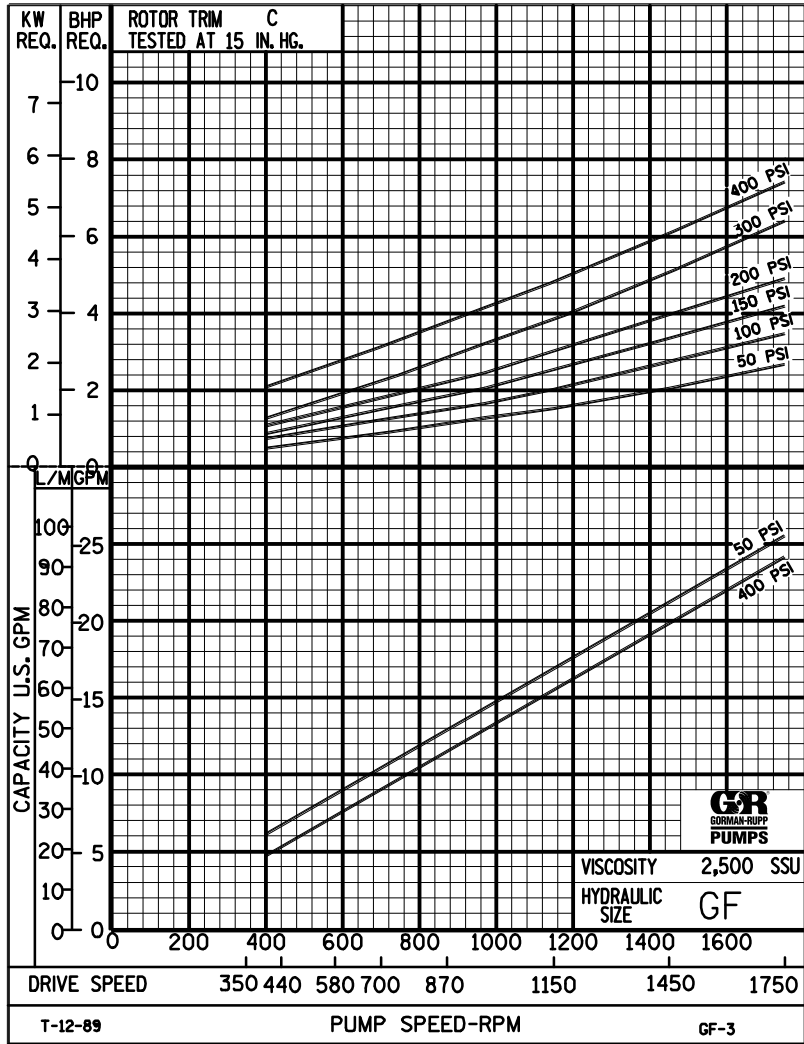

**THE GORMAN-RUPP COMPANY • MANSFIELD, OHIO**  
 GORMAN-RUPP OF CANADA LIMITED • ST. THOMAS, ONTARIO, CANADA



# GF

## PUMP HYDRAULIC SIZE CHART

SEC. 500

Page 46

January 2010

**23 GPM  
1750 RPM**

NOMINAL		ROTOR TRIM	VISCOSITY (SSU)	N.I.P.R. (PSIA)	FRICTION PIPE LOSS (PSI/FT) <small>(Based on Sch 40 Steel Pipe)</small>					FULL BYPASS RELIEF VALVE PRESSURE (PSI)					CAPACITY (GPM) / H.P. REQUIRED										
CAP. GPM	SPEED RPM				PIPE DIAMETER					CRACKING PRESS. (PSI)					DIFFERENTIAL PRESSURE (PSI)										
					3/4"	1"	1 1/4"	1 1/2"	2"	LOW PRES R/V			HI PRES R/V		MEDIUM DUTY AND HEAVY DUTY				HEAVY DUTY ONLY						
							50	75	100	150	200	25	50	75	100	150	200	300	400						
23	1750	STD	28	3.9	.01	.01	.01	.01	.01	63	89	117			21	20	19	18							
			32		.36	.12	.03	.02	.01					.69	1.1	1.5	1.9								
			38	3.9	.46	.15	.04	.02	.01	63	89	117	167			22	21	21	19	18					
			50		.56	.18	.05	.03	.01					.92	1.1	1.7	2.1	2.9							
			70	3.9	.63	.20	.06	.03	.01	64	90	119	167	230			23	23	22	21	20	20			
			100		.74	.24	.07	.03	.01							1.1	1.4	1.8	2.2	3.1	3.8				
			150	3.9	.83	.27	.08	.04	.01	64	90	119	167	230			24	24	23	22	22	22	21	19	
			200		.87	.31	.10	.05	.02							1.4	1.6	2.1	2.4	3.2	3.9	5.3	6.6		
			300	3.9	.90	.34	.12	.06	.03	65	91	123	167	230			25	24	24	23	23	23	22	21	
			500		1.47	.56	.19	.10	.04							1.6	1.9	2.4	2.7	3.4	4.2	5.6	6.9		
		750	3.9	2.20	.84	.28	.15	.06	65	91	123	167	230			25	25	25	24	24	24	24	23		
		1,000		2.94	1.12	.38	.20	.08							1.8	2.2	2.7	3.0	3.7	4.4	5.8	7.1			
				"C"	2,000	5.0	5.87	2.24	.75	.40	.15	69	97	124	168	232	25	25	25	25	25	24	24	24	
					3,500		10.3	3.91	1.31	.71	.26							2.4	2.9	3.6	3.7	4.4	4.9	6.4	7.6
					5,000	5.8	14.7	5.59	1.87	1.01	.37	74	100	127	170	233	25	25	25	25	25	25	24	24	
					7,500		22.0	8.40	2.80	1.51	.56							3.1	3.4	4.1	4.4	5.1	5.8	7.3	8.3
					10,000	6.5	29.4	11.2	3.73	2.01	.74	79	104	130	172	233	25	25	25	25	25	25	25	24	
					15,000		44.0	16.8	5.60	3.02	1.11							3.7	4.1	4.6	5.2	5.9	6.6	8.2	9.3
				20,000	7.1	58.7	22.4	7.46	4.03	1.48	84	109	134	175	234	25	25	25	25	25	25	25	24		
				25,000		73.4	28.0	9.32	5.03	1.85							4.2	4.6	5.5	6.2	7.0	7.8	9.3	11	
		50,000																							
		75,000																							
		100,000																							
		150,000																							
		200,000																							
		250,000																							

(NOTE) For speeds not shown on the pump hydraulic charts, consult factory.



# GF

## PUMP HYDRAULIC SIZE CHART

SEC. 500

Page 47

January 2010

**15 GPM  
1150 RPM**

NOMINAL		ROTOR TRIM	VISCOSITY (SSU)	N.I.P.R. (PSIA)	FRICTION PIPE LOSS (PSI/FT) <small>(Based on Sch 40 Steel Pipe)</small>					FULL BYPASS RELIEF VALVE PRESSURE (PSI)					CAPACITY (GPM) / H.P. REQUIRED											
CAP. GPM	SPEED RPM				PIPE DIAMETER					CRACKING PRESS. (PSI)					DIFFERENTIAL PRESSURE (PSI)											
							LOW PRES R/V		HI PRES R/V			MEDIUM DUTY AND HEAVY DUTY				HEAVY DUTY ONLY										
					3/4"	1"	1 1/4"	1 1/2"	2"	50	75	100	150	200	25	50	75	100	150	200	300	400				
15	1150	STD	28	2.2	.01	.01	.01	.01	.01	59	86	111			13	11	10	9.5								
			32		.17	.06	.02	.01	.01						.56	.72	.96	1.2								
			38	2.2	.22	.07	.02	.01	.01	59	86	111	161			13	13	11	11	9.5						
			50		.27	.09	.03	.01	.01							.62	.78	1.0	1.3	1.8						
			70	2.2	.30	.10	.03	.01	.01	60	87	113	163	215			14	14	13	12	12	11				
			100		.36	.12	.03	.02	.01								.66	.83	1.1	1.4	1.9	2.4				
			150	2.2	.41	.14	.05	.02	.01	60	87	113	163	217			15	15	14	14	13	13	13	13	12	
			200		.46	.18	.06	.03	.01								.78	.98	1.2	1.5	1.9	2.4	3.5	4.6		
			300	2.2	.58	.22	.08	.04	.02	60	87	115	165	219			16	15	15	15	15	14	14	14	13	
			500		.96	.37	.12	.07	.03								.94	1.2	1.4	1.6	2.1	2.6	3.6	4.7		
		750	2.2	1.44	.55	.18	.10	.04	60	87	115	165	222			16	16	16	16	16	15	15	15	14		
		1,000		1.92	.73	.25	.13	.05								1.1	1.3	1.5	1.7	2.2	2.7	3.7	4.8			
				"C"	2,000	2.8	3.83	1.46	.49	.26	.10	62	90	115	165	222										
					3,500		6.70	2.55	.85	.46	.17															1.4
					5,000	3.2	9.57	3.64	1.22	.66	.24	65	92	117	167	224										
					7,500		14.4	5.46	1.83	.99	.36															
					10,000	3.6	19.1	7.29	2.43	1.31	.49	68	94	119	169	224										
					15,000		28.7	10.9	3.65	1.97	.73															
				20,000	3.9	38.3	14.6	4.87	2.63	.97	72	97	122	172	224											
				25,000		47.8	18.2	6.08	3.28	1.21																2.2
		50,000	6.1	95.7	36.4	12.2	6.56	2.42	77	102	127	177	229													
		75,000		144	54.6	18.3	9.85	3.63																3.6	4.5	5.1
		100,000																								
		150,000																								
		200,000																								
		250,000																								

(NOTE) For speeds not shown on the pump hydraulic charts, consult factory.



# GF

## PUMP HYDRAULIC SIZE CHART

SEC. 500

Page 48

January 2010

11 GPM  
870 RPM

NOMINAL		ROTOR TRIM	VISCOSITY (SSU)	N.I.P.R. (PSIA)	FRICTION PIPE LOSS (PSI/FT) <small>(Based on Sch 40 Steel Pipe)</small>					FULL BYPASS RELIEF VALVE PRESSURE (PSI)					CAPACITY (GPM) / H.P. REQUIRED																
CAP. GPM	SPEED RPM				PIPE DIAMETER					CRACKING PRESS. (PSI)					DIFFERENTIAL PRESSURE (PSI)																
					3/4"	1"	1 1/4"	1 1/2"	2"	LOW PRES R/V		HI PRES R/V			MEDIUM DUTY AND HEAVY DUTY				HEAVY DUTY ONLY												
11	870	STD	28	1.5	.01	.01	.01	.01	.01	57	82	107			9	8	7	6													
			32		.10	.03	.01	.01	.01							.32	.53	.71	.91												
			38	1.5	.13	.04	.01	.01	.01	57	82	107	158			10	9	8	7.5	6.5											
			50		.16	.05	.02	.01	.01						.50	.59	.85	1.1	1.4												
			70	1.5	.18	.06	.02	.01	.01	57	82	108	159	210			10	10	9.5	9	8	7									
			100		.21	.06	.02	.01	.01						.54	.63	.88	1.1	1.5	1.8											
			150	1.5	.26	.09	.03	.01	.01	58	83	109	159	212			11	11	10	10	10	9.5	9.5	8							
			200		.33	.12	.05	.02	.01						.61	.71	.94	1.2	1.5	1.8	2.5	3.3									
			300	1.5	.43	.16	.06	.03	.01	58	83	110	160	213			12	12	11	11	11	10	10	9.5							
			500		.70	.27	.09	.05	.02						.69	.81	1.0	1.3	1.6	1.9	2.5	3.5									
			750	1.5	1.05	.40	.14	.07	.03	58	83	112	162	215			12	12	12	12	12	11	11	11							
			1,000		1.41	.54	.18	.10	.04						.79	.93	1.1	1.3	1.7	2.0	2.6	3.6									
		2,000	2.0	2.81	1.07	.36	.19	.07	59	86	113	163	215			13	12	12	12	12	12	11	11								
		3,500		4.91	1.87	.63	.34	.13						.98	1.2	1.3	1.5	1.8	2.2	2.8	3.7										
		5,000	2.4	7.02	2.67	.89	.48	.18	61	86	113	163	215			13	12	12	12	12	12	12	11								
		7,500		10.5	4.00	1.34	.72	.27						1.3	1.5	1.7	1.9	2.2	2.6	3.2	4.1										
		10,000	2.7	14.0	5.34	1.78	.96	.36	64	89	115	167	217			13	12	12	12	12	12	12	12								
		15,000		21.1	8.01	2.68	1.45	.53						1.5	1.8	2.1	2.3	2.6	2.9	3.6	4.4										
		20,000	3.0	28.1	10.7	3.57	1.93	.71	67	92	117	169	219			13	12	12	12	12	12	12	12								
		25,000		35.1	13.4	4.46	2.41	.89						1.9	2.2	2.4	2.5	2.9	3.3	4.1	4.8										
		50,000	4.9	70.2	26.7	8.92	4.81	1.77	70	95	123	173	225			13	12	12	12	12	12	12	12								
		75,000		105	40.1	13.4	7.22	2.66						2.9	3.4	3.6	3.8	4.2	4.6	5.4	6.1										
		100,000	7.1	140	53.4	17.9	9.63	3.55	74	99	127	177	231			12	12	12	12	12	12	12	12								
		150,000		211	80.1	26.8	14.5	5.32						3.6	4.3	4.5	4.7	5.1	5.4	6.2	6.9										
200,000																															
250,000																															

(NOTE) For speeds not shown on the pump hydraulic charts, consult factory.

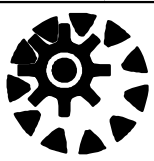

# GF

## PUMP HYDRAULIC SIZE CHART

SEC. 500

Page 49

January 2010

**8 GPM  
580 RPM**

NOMINAL		ROTOR TRIM	VISCOSITY (SSU)	N.I.P.R. (PSIA)	FRICTION PIPE LOSS (PSI/FT) <small>(Based on Sch 40 Steel Pipe)</small>					FULL BYPASS RELIEF VALVE PRESSURE (PSI)					CAPACITY (GPM)				H.P. REQUIRED										
CAP. GPM	SPEED RPM				PIPE DIAMETER					CRACKING PRESS. (PSI)					25	50	75	100	150	200	300	400							
			3/4"	1"	1 1/4"	1 1/2"	2"	LOW PRES R/V		HI PRES R/V			MEDIUM DUTY AND HEAVY DUTY										HEAVY DUTY ONLY						
8	580	STD	28	1.1	.01	.01	.01	.01	.01	56	81	106			6	5	4.5	4											
			32		.06	.02	.01	.01	.01							.21	.35	.47	.61										
			38	1.1	.07	.03	.01	.01	.01	56	81	106	157			6.5	6	5.5	4.5	4									
			50		.09	.03	.01	.01	.01							.34	.40	.57	.74	.92									
			70	1.1	.10	.04	.01	.01	.01	56	81	107	158	209		7	6.5	6	6	5.5	4.5								
			100		.10	.04	.01	.01	.01							.36	.42	.59	.76	.98	1.2								
			150	1.1	.15	.05	.02	.01	.01	57	82	108	158	211		7.5	7.5	7	6.5	6.5	6	6	6	6	6	6	5		
			200		.24	.08	.03	.02	.01							.41	.48	.63	.78	1.0	1.2	1.7	2.2						
			300	1.1	.31	.12	.04	.02	.01	57	82	109	159	212		8	8	7.5	7	7	7	6.5	6						
			500		.51	.19	.07	.04	.01							.46	.54	.69	.84	1.1	1.3	1.7	2.3						
			750	1.1	.77	.29	.10	.05	.02	57	82	111	161	214		8.5	8	8	8	8	7	7.5	7						
			1,000		1.02	.39	.14	.07	.03							.53	.62	.76	.89	1.1	1.4	1.7	2.4						
					2,000	1.5	2.04	.78	.26	.14	.05	58	85	112	162	214	8.5	8.5	8	8	8	8	7.5	7.5					
					3,500		3.57	1.36	.46	.25	.09						.66	.77	.88	.99	1.2	1.5	1.9	2.5					
				5,000	1.9	5.01	1.94	.65	.35	.13	60	85	112	162	214	8.5	8.5	8	8	8	8	8	7.5						
				7,500		7.65	2.91	.97	.53	.19						.84	.99	1.1	1.3	1.5	1.7	2.1	2.7						
				10,000	2.2	10.2	3.88	1.30	.70	.26	63	88	114	166	216	8.5	8.5	8	8	8	8	8	7.5						
				15,000		15.3	5.83	1.95	1.05	.39						1.0	1.2	1.3	1.4	1.6	1.9	2.4	2.9						
				20,000	2.5	20.4	7.77	2.59	1.40	.52	66	91	116	168	218	8.5	8.5	8	8	8	8	8	8						
				25,000		25.5	9.71	3.24	1.75	.65						1.0	1.2	1.4	1.5	1.7	2.0	2.5	3.0						
				50,000	4.0	51.1	19.4	6.50	3.50	1.29	68	93	120	170	222	8.5	8.5	8	8	8	8	8	8						
				75,000		76.5	29.1	9.73	5.25	1.93						1.6	1.9	2.1	2.2	2.4	2.7	3.2	3.7						
				100,000	6.0	102	38.9	13.0	7.00	2.58	70	95	122	172	224	8.5	8	8	8	8	8	8	8						
				150,000		153	58.3	19.5	10.5	3.87						2.1	2.5	2.6	2.7	3.0	3.2	3.7	4.2						
		200,000	9.4	204	77.7	26.0	14.0	5.15	76	101	130	180	236	8.5	8.5	8.5	8.5	8	8	8	8								
		250,000		-	-	-	-	-						2.5	3.0	3.1	3.2	3.4	3.7	4.2	4.7								

(NOTE) For speeds not shown on the pump hydraulic charts, consult factory.