

**GHS SERIES
 FLEXIBLE SEAL
 HEAVY DUTY STANDARD
 STAINLESS STEEL ROTARY
 GEAR PUMP**

This heavy duty series with internal “wetted” parts of 316 Stainless Steel is ideal for handling corrosive applications. Superior rotor shaft support and an integral maintenance-free radial/thrust bearing, reduce deflection and wear. Due to the “galling” nature of stainless, extra internal clearance is necessary. A capacity correction table for liquids less than 750 SSU is available in Section 500.

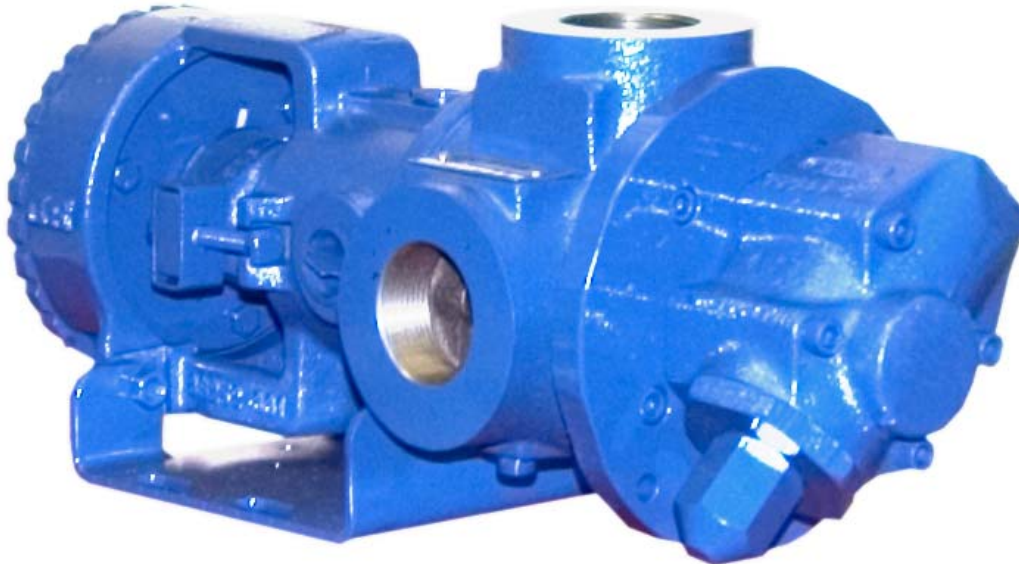

SHOWN ^W/INTERCHANGE FOOT BRACKET

The GHS stainless series is designed for applications in the operating ranges noted below. These units are available with head and backhead jackets for temperature control, silicon carbide bushings for wear resistance, and numerous shaft seal options described on the following pages.

FEATURES

- 200 PSI CAPABILITY
- BALL BEARING THRUST CONTROL
- ROTOR END CLEARANCE EXTERNALLY ADJUSTABLE
- EXCEPTIONAL SEAL VERSATILITY WITH INTERNAL SEAL VENT
- COMPUTER PROFILED GEARING FOR QUIET OPERATION
- MULTIPLE PORT POSITIONS
- FLEXIBLE SEAL DESIGN ALLOWS FOR A VARIETY OF INDUSTRY STANDARD SEALS OR PACKING

OPERATING RANGE

- CAPACITY (GPM): (3 TO 295)
 [LPM] : [11 TO 1116]
- PRESSURE (PSI) : [0 TO 200]
 [BAR] : [0 TO 14]
- VISCOSITY (SSU) : (28 TO 2,000,000)
 [cSt] : [1 TO 440,000]
- TEMPERATURE (F) : (-30° TO 675°)
 [C] : [-34° TO 358°]

APPLICATIONS

- USE WITH ANY CLEAN LIQUID COMPATIBLE WITH 316 STAINLESS STEEL
- ★ BOOSTER SERVICE
 - ★ CIRCULATING
 - ★ FILTERING
 - ★ LUBRICATING
 - ★ TRANSFERRING

EXTERIOR	BACKH.D	ROTOR & IDLER	HOUSING PORTS	BUSHING	IDLER PIN	SHAFT	SHAFT SEALING		ROTA-TION	INTERNAL RELIEF VALVE	
							MECH. SEAL	PACKING		MATERIAL	SETTING
316 STAIN. STEEL	CAST IRON	316 STAIN. STEEL	GHC 180° FLG. GHS 90° NPT	CARBON GRAPHITE	COATED 316 SST	STAIN. STEEL	CARBON, SIC, TEFLON ENC.	CARBON FIBER	C.W.	316 STAINLESS STEEL	75 PSI [5 BAR]

G H C 1 DC 9 - B
G H S 1 DC 9 - B
 | | | | | | | | | | | |
 GEAR DUTY DESIGN PORT SIZE HYD. SIZE SEAL STYLE

Standard Models

MODEL NUMBER		NOM. CAPACITY - SPEED				MAXIMUM				SHIPPING DATA	
		MAXIMUM		ALTERNATIVE		DIFF. PRESSURE - PSI [BAR]			TEMP.	Wt.	Vol.
		GPM [LPM]	RPM 60 Hz [50 HZ]	GPM [LPM]	RPM 60 Hz [50 HZ]	BELOW 38 SSU [4 cSt]	38 TO 100 SSU [21 cSt]	100 TO 250,000 SSU [55,000 cSt]	°F [°C]		
GHC 1 DC9-B ① ● ▸	GHS 1 DC9-B ① ● ● GHS 1 DC10-B ① ● ■	9 [28]		6 [19]						32 [14,5]	2.9
GHC 1 DE9-B ① ● ● ▸	GHS 1 DE9-B ① ● ● ● GHS 1 DE10-B ① ● ● ■	11 [35]		7 [22]						32 [14,5]	2.9
GHC 1-1/2 GC9-B ● ● ▸	GHS 1-1/2 GC9-B ● ● ● GHS 1-1/2 GC10-B ● ● ■	16 [50]		10 [32]						63 [28,6]	2.9
	GHS 2 GC9-B ● ● ● GHS 2 GC10-B ● ● ■									63 [28,6]	2.9
GHC 1-1/2 GF9-B ● ● ▸	GHS 1-1/2 GF9-B ● ● ● ● GHS 1-1/2 GF10-B ● ● ● ■	23 [73]	1750 [1460]	15 [47]	1150 [960]					GHC ● 63 [28,6] 2.9 350 [177] 63 [28,6] 2.9	
	GHS 2 GF9-B ● ● ● ● GHS 2 GF10-B ● ● ● ■									GHS ● 63 [28,6] 2.9 400 [204] 63 [28,6] 2.9	
GHC 1-1/2 GH9-B ● ● ▸	GHS 1-1/2 GH9-B ● ● ● ● GHS 1-1/2 GH10-B ● ● ● ■	31 [98]		20 [63]		75 [5]	100 [7]	200 [14]		63 [28,6] 2.9 63 [28,6] 2.9	
	GHS 2 GH9-B ● ● ● ● GHS 2 GH10-B ● ● ● ■									63 [28,6] 2.9	
GHC 1-1/2 GJ9-B ● ● ▸	GHS 1-1/2 GJ9-B ● ● ● ● GHS 1-1/2 GJ10-B ● ● ● ■	38 [120]		25 [79]						63 [28,6] 2.9	
	GHS 2 GJ9-B ● ● ● ● GHS 2 GJ10-B ● ● ● ■									63 [28,6] 2.9	
	GHS 2 JG9-B ● ● ● ● GHS 2 JG10-B ● ● ● ■	40 [126]	1150 [960]	30 [95]	870 [725]					161 [73,2] 5.3	
GHC 3 JG9-B ● ● ▸	GHS 3 JG9-B ● ● ● ● GHS 3 JG10-B ● ● ● ■									161 [73,2] 5.3	
	GHS 2 JJ9-B ● ● ● ● GHS 2 JJ10-B ● ● ● ■	56 [177]		42 [133]						161 [73,2] 5.3	
GHC 3 JJ9-B ● ● ▸	GHS 3 JJ9-B ● ● ● ● GHS 3 JJ10-B ● ● ● ■									161 [73,2] 5.3	

STANDARD MODELS CONTINUED

① 3450 [2875] RPM PERMISSIBLE TO 1,000 SSU [220 cSt.] AND 100 PSI [7 BAR]

● MECHANICAL SEAL
■ PACKING/LIP SEAL

▸ PORTS ARE COMPATIBLE WITH 150# ANSI FLANGES. ALL OTHER PORTS ARE TAPPED NPT FOR ANSI PIPE. OPTIONAL [DIN] FLANGES OR TAPPED [BSP] PORTS ARE AVAILABLE FOR EXPORT MARKET.

NOTE: RECOMMENDED PORT SIZES ARE SHOWN IN **BOLDFACE**. EXAMPLE: **GHC 1 DC9-B**, **GHS 1 DC9-B**

THE GORMAN-RUPP COMPANY • MANSFIELD, OHIO

GORMAN-RUPP OF CANADA LIMITED • ST. THOMAS, ONTARIO, CANADA

Standard Models (Continued)

MODEL NUMBER		NOM. CAPACITY - SPEED				MAXIMUM				SHIPPING DATA	
		MAXIMUM		ALTERNATIVE		DIFF. PRESSURE - PSI [BAR]			TEMP.	Wt.	Vol.
		GPM [LPM]	RPM 60 Hz [50 HZ]	GPM [LPM]	RPM 60 Hz [50 HZ]	BELOW 38 SSU [4 cSt]	38 TO 100 SSU [21 cSt]	100 TO 250,000 SSU [55,000 cSt]	°F [°C]	LBS [KG]	CU. FT.
GHC	GHS 2 JL9-B ●	77 [243]	1150 [960]	58 [133]	870 [725]	75 [5]	100 [7]	200 [14]	GHC	161 [73,2]	5.3
	GHS 2 JL10-B ■									161 [73,2]	
GHC 3 JL9-B ● †	GHS 3 JL9-B ●	107 [338]	960 [960]	81 [256]	580 [480]	75 [5]	100 [7]	200 [14]	GHC	161 [73,2]	5.3
	GHS 3 JL10-B ■									161 [73,2]	
GHC 3 JP9-B ● †	GHS 2 JP9-B ●	99 [375]	960 [960]	80 [252]	580 [480]	75 [5]	100 [7]	200 [14]	GHC	161 [73,2]	5.3
	GHS 2 JP10-B ■									161 [73,2]	
GHC 3 JP9-B ● †	GHS 3 JP9-B ●	132 [500]	960 [960]	80 [252]	580 [480]	75 [5]	100 [7]	200 [14]	GHC	161 [73,2]	5.3
	GHS 3 JP10-B ■									161 [73,2]	
GHC	GHS 2 NK9-B ●	165 [624]	960 [960]	99 [312]	580 [480]	75 [5]	100 [7]	200 [14]	GHC	180 [81,8]	5.3
	GHS 2 NK10-B ■									180 [81,8]	
GHC	GHS 2-1/2 NK9-B ●	172 [542]	960 [960]	115 [362]	580 [480]	75 [5]	100 [7]	200 [14]	GHC	180 [81,8]	5.3
	GHS 2-1/2 NK10-B ■									180 [81,8]	
GHC	GHS 3 NK9-B ●	215 [678]	960 [960]	115 [362]	580 [480]	75 [5]	100 [7]	200 [14]	GHC	180 [81,8]	5.3
	GHS 3 NK10-B ■									180 [81,8]	
GHC	GHS 2 NM9-B ●	172 [542]	960 [960]	80 [252]	580 [480]	75 [5]	100 [7]	200 [14]	GHC	180 [81,8]	5.3
	GHS 2 NM10-B ■									180 [81,8]	
GHC	GHS 2-1/2 NM9-B ●	172 [542]	960 [960]	80 [252]	580 [480]	75 [5]	100 [7]	200 [14]	GHC	180 [81,8]	5.3
	GHS 2-1/2 NM10-B ■									180 [81,8]	
GHC	GHS 3 NM9-B ●	172 [542]	960 [960]	80 [252]	580 [480]	75 [5]	100 [7]	200 [14]	GHC	180 [81,8]	5.3
	GHS 3 NM10-B ■									180 [81,8]	
GHC	GHS 2-1/2 NP9-B ●	172 [542]	960 [960]	99 [312]	580 [480]	75 [5]	100 [7]	200 [14]	GHC	180 [81,8]	5.3
	GHS 2-1/2 NP10-B ■									180 [81,8]	
GHC	GHS 3 NP9-B ●	172 [542]	960 [960]	99 [312]	580 [480]	75 [5]	100 [7]	200 [14]	GHC	180 [81,8]	5.3
	GHS 3 NP10-B ■									180 [81,8]	
GHC	GHS 2 RM9-B ●	172 [542]	960 [960]	115 [362]	580 [480]	75 [5]	100 [7]	200 [14]	GHC	357 [162]	10.7
	GHS 2 RM10-B ■									357 [162]	
GHC	GHS 2-1/2 RM9-B ● †	172 [542]	960 [960]	115 [362]	580 [480]	75 [5]	100 [7]	200 [14]	GHC	357 [162]	10.7
	GHS 2-1/2 RM10-B ■ †									357 [162]	
GHC	GHS 3 RM9-B ● †	172 [542]	960 [960]	115 [362]	580 [480]	75 [5]	100 [7]	200 [14]	GHC	357 [162]	10.7
	GHS 3 RM10-B ■ †									357 [162]	
GHC	GHS 4 RM9-B ● †	172 [542]	960 [960]	115 [362]	580 [480]	75 [5]	100 [7]	200 [14]	GHC	357 [162]	10.7
	GHS 4 RM10-B ■ †									357 [162]	
GHC	GHS 3 RP9-B ● †	215 [678]	720 [600]	143 [451]	480 [400]	75 [5]	100 [7]	200 [14]	GHC	357 [162]	10.7
	GHS 3 RP10-B ■ †									357 [162]	
GHC	GHS 4 RP9-B ● †	215 [678]	720 [600]	143 [451]	480 [400]	75 [5]	100 [7]	200 [14]	GHC	357 [162]	10.7
	GHS 4 RP10-B ■ †									357 [162]	

STANDARD MODELS CONTINUED

- MECHANICAL SEAL
- PACKING/LIP SEAL

† PORTS ARE COMPATIBLE WITH 150# ANSI FLANGES. ALL OTHER PORTS ARE TAPPED NPT FOR ANSI PIPE. OPTIONAL [DIN] FLANGES OR TAPPED [BSP] PORTS ARE AVAILABLE FOR EXPORT MARKET.

NOTE: RECOMMENDED PORT SIZES ARE SHOWN IN **BOLDFACE**. EXAMPLE: **GHC 1 DC9-B, GHS 1 DC9-B**

THE GORMAN-RUPP COMPANY • MANSFIELD, OHIO
 GORMAN-RUPP OF CANADA LIMITED • ST. THOMAS, ONTARIO, CANADA

MODEL NUMBER		NOM. CAPACITY - SPEED				MAXIMUM				SHIPPING DATA	
		MAXIMUM		ALTERNATIVE		DIFF. PRESSURE - PSI [BAR]			TEMP.	Wt.	Vol.
		GPM [LPM]	RPM 60 Hz [50 HZ]	GPM [LPM]	RPM 60 Hz [50 HZ]	BELOW 38 SSU [4 cSt]	38 TO 100 SSU [21 cSt]	100 TO 250,000 SSU [55,000 cSt]	°F [°C]	LBS [KG]	CU. FT.
GHC	GHS										
	GHS 3 RR9-B ● ▸ GHS 3 RR10-B ■ ▸	255 [804]	720 [600]	170 [536]	480 [400]	75 [5]	100 [7]	200 [14]	GHS ● 400 [204] ■ 500 [260]	357 [162]	10.7
	GHS 4 RR9-B ● ▸ GHS 4 RR10-B ■ ▸			196 [618]						357 [162]	
	GHS 4 RS9-B ● ▸ GHS 4 RS10-B ■ ▸			295 [930]						357 [162]	

▸ PORTS ARE COMPATIBLE WITH 150# ANSI STAINLESS STEEL FLANGES. ALL OTHER PORTS ARE TAPPED NPT FOR ANSI PIPE. OPTIONAL [DIN] FLANGES OR TAPPED [BSP] PORTS AVAILABLE FOR EXPORT MARKET.

NOTE: RECOMMENDED PORT SIZES ARE SHOWN IN BOLDFACE. EXAMPLE: **GHC 1 DC9-B, GHS 1 DC9-B**

APPLICATION RECOMMENDATIONS:		
APPLICATION	OPTIONS REQUIRED (Select One From Each Row)	OPERATING LIMITATIONS
GHS ONLY HIGH TEMPERATURE	25U, 25V, OR 25W 35J – 35M (AS REQ'D) 40R, 70K 61H OR 65Q	TEMPERATURE: 675 °F MAX. PRESSURE: 200 PSI MAX.
GHS ONLY JACKETED	40K, 40W, 41U, 41W	LIMIT JACKET PRESSURE TO 150 PSI

NOTE: PROPER PUMP APPLICATION REQUIRES CONSIDERATION OF ADDITIONAL FACTORS. PLEASE REVIEW APPLICATION GUIDE IN SECTION 500 OR CONSULT THE FACTORY.

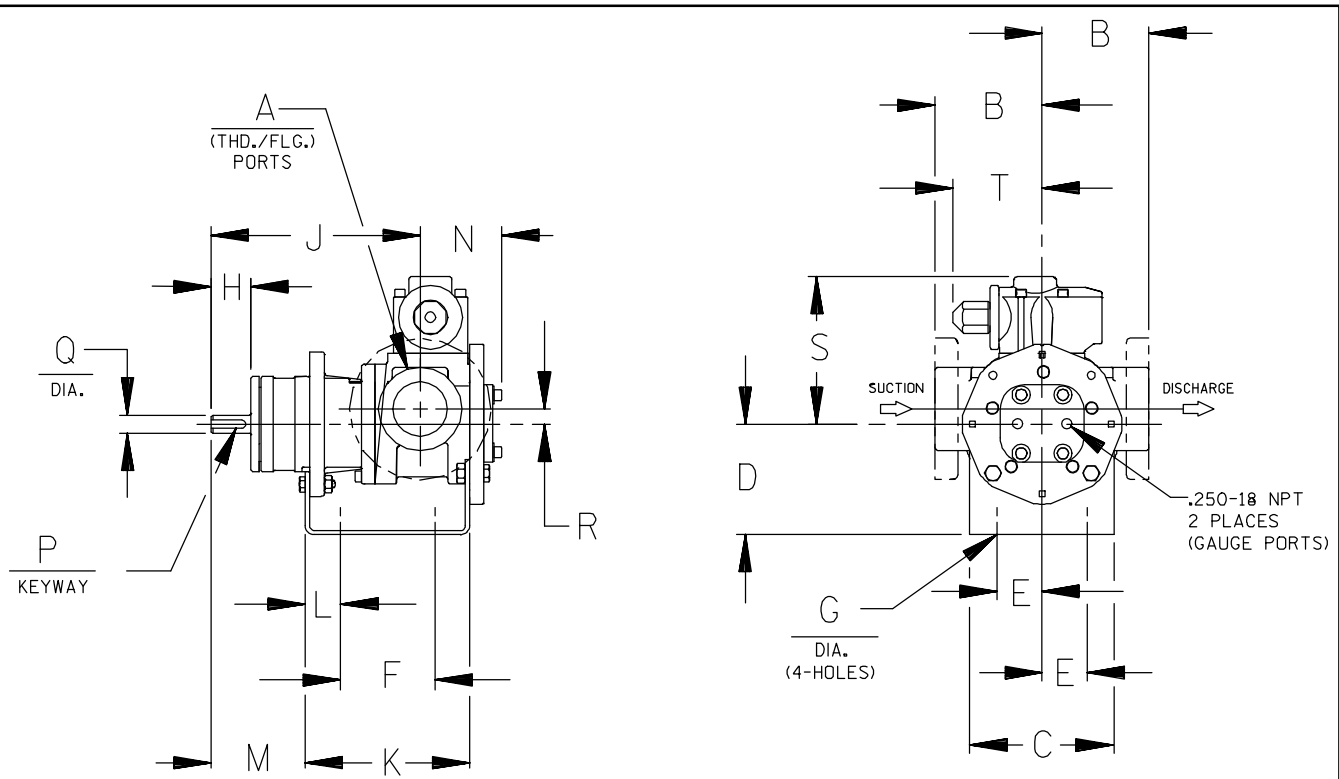

CAD FILE NO.: 16458B

MODEL NUMBERS	PUMP DIMENSIONS - INCHES [MILLIMETERS]																	
	A	B	C	D	E	F	G	H	J	K	L	M	N	P	Q	R	S	T
GHC D	1"	2.50 [64] †	4.00 [102]	3.50* [89]	1.62 [41]	3.12 [79]	.41 [10]	1.16 [30]	6.19 [157]	5.04 [128]	.76 [19]	2.62 [66]	2.74 [70]	.12 [3]	.50 [13]	.62 [16]	5.19 [132]	3.58 [91]
		4.00* [102] †		5.25 [133]										.75 [19]				
GHC G	1-1/2"	3.50 [89] †	5.88 [149]	3.50* [89]	1.62 [41]	4.00 [102]	.41 [10]	1.62 [41]	8.50 [216]	6.71 [170]	1.06 [27]	3.82 [97]	3.35 [85]	.19 [5]	.75 [19]	.62 [16]	6.00 [152]	3.62 [92]
		4.00* [102] †		4.50 [114]										5.25 [133]				
GHC J	3"	4.50 [114] †	6.88 [175]	4.50 [114]	2.88 [73]	4.25 [108]	.44 [11]	2.50 [64]	12.12 [308]	9.75 [248]	1.75 [44]	5.50 [140]	4.66 [118]	.25 [6]	1.00 [25]	1.12 [28]	9.06 [230]	6.75 [171]
		6.00* [152] †		5.25* [133]										6.25 [159]				

* STANDARD DIMENSION

† PORTS ARE COMPATIBLE WITH 125* OR 250* ANSI CAST IRON FLANGES. ALL OTHER PORTS ARE TAPPED NPT FOR ANSI PIPE. OPTIONAL (DIN) FLANGES OR TAPPED (BSP) PORTS AVAILABLE FOR EXPORT MARKET.

† 90° HOUSING

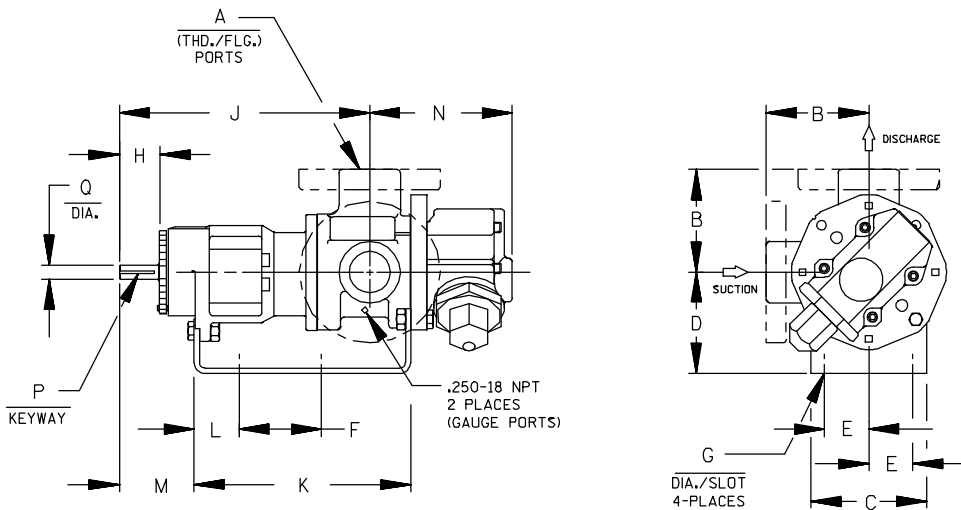

CAD FILE NO.: 16669G

MODEL NUMBERS	PUMP DIMENSIONS - INCHES [MILLIMETERS]														
	A	B	C	D	E	F	G	H	J	K	L	M	N	P	Q
GHS D	1"	2.50* [64]	4.00 [102]	3.50* [89]	1.62 [41]	5.50 [140]	.41 [10]	1.16 [30]	8.43 [214]	7.54 [192]	1.09 [28]	2.29 [58]	4.98 [127]	.12 [3] x .75 [19]	.50 [13]
		4.00 † [102]		5.25 [133]											
GHS G	1-1/2" 2"	3.50* [89]	4.88 [124]	3.50* [89]	1.62 [41]	8.00 [203]	.41 [10]	1.62 [41]	12.06 [306]	10.72 [272]	1.52 [39]	3.35 [85]	5.70 [145]	.19 [5] x 1.25 [32]	.75 [19]
		4.00 † [102]		5.25 [133]											
GHS J	2" 3"	4.50* [114]	6.88 [175]	5.25* [133]	2.88 [73]	10.00 [254]	.44 [11]	2.50 [64]	15.68 [398]	14.31 [363]	2.77 [70]	4.48 [114]	8.50 [216]	.25 [6] x 2.00 [51]	1.00 [25]
		6.00 † [152]		6.25 [159]											
GHS N	2" 3"	5.12 [130]	8.00 [203]	4.50 [114]	2.88 [73]	10.00 [254]	.44 [11]	2.58 [66]	16.37 [416]	15.14 [385]	2.69 [68]	4.56 [116]	8.72 [221]	.25 [6] x 2.00 [51]	1.12 [28]
				5.25* [133]											
GHS R	2"	6.50 [165]	10.50 [267]	7.00 [178]	3.75 [95]	13.75 [349]	.52 [13]	2.25 [57]	17.87 [454]	17.36 [441]	1.86 [47]	4.70 [119]	11.31 [287]	.38 [10] x 1.88 [48]	1.44 [37]
	2-1/2"														
	3"														
	4"	7.19 † [183]													

* STANDARD DIMENSION

† PORTS ARE COMPATIBLE WITH 150# OR 300# ANSISTAINLESS STEEL FLANGES. ALL OTHER PORTS ARE TAPPED NPT FOR ANSI PIPE. OPTIONAL (DIN) FLANGES OR TAPPED (BSP) PORTS AVAILABLE FOR EXPORT MARKET.

† 180° HOUSING

GHC/GHS

FOR GHC DRIVE OPTIONS

AND DIMENSIONS

SEE SECTION 540

FOR GHS DRIVE OPTIONS

AND DIMENSIONS

SEE SECTION 545



PERFORMANCE CURVES

SPEED VS. CAPACITY/HORSEPOWER

NP Hydraulic Size

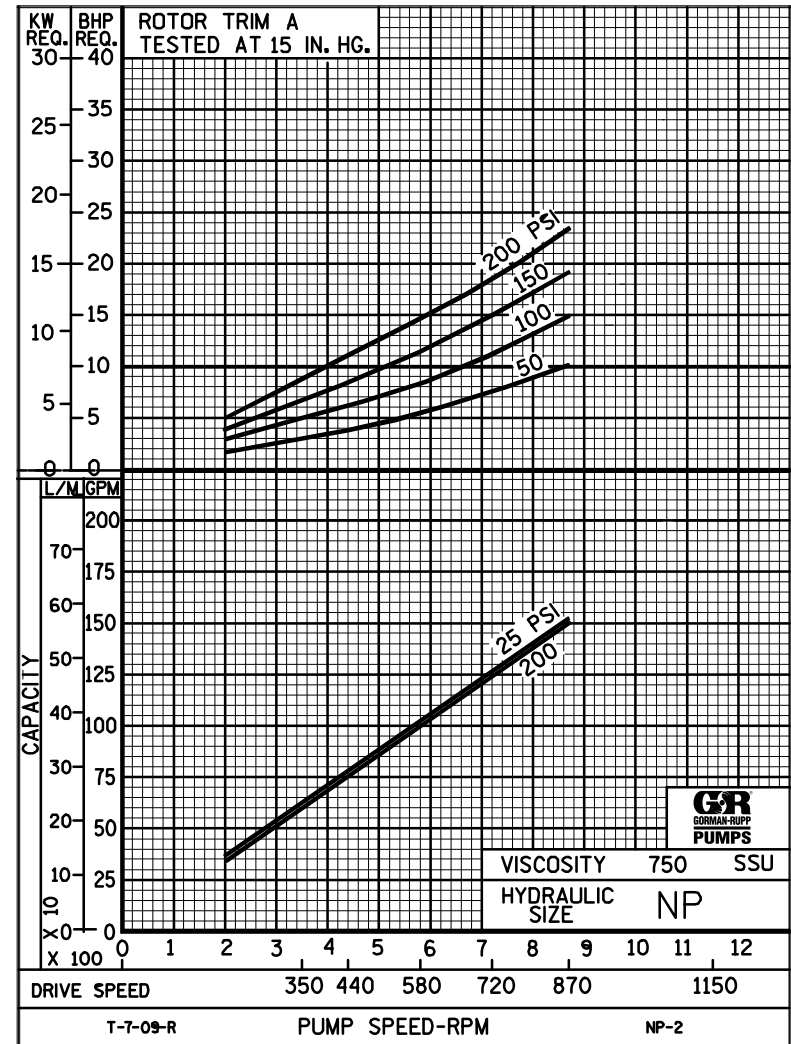
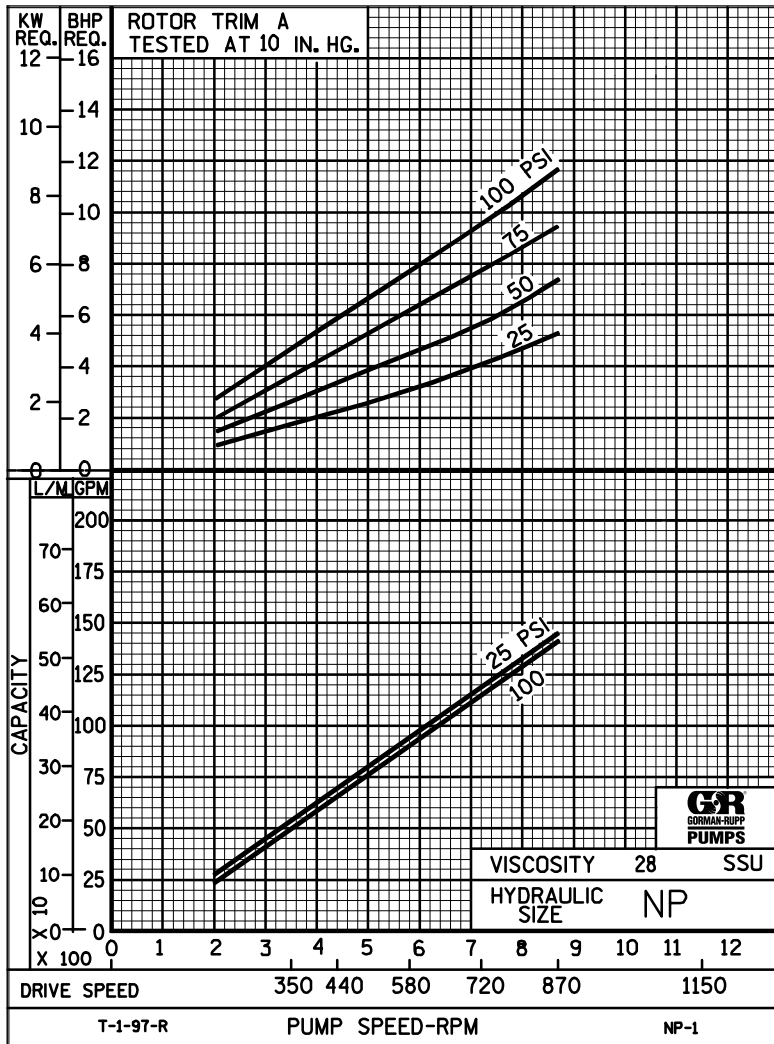

THE GORMAN-RUPP COMPANY • MANSFIELD, OHIO
 GORMAN-RUPP OF CANADA LIMITED • ST. THOMAS, ONTARIO, CANADA



PERFORMANCE CURVES

SPEED VS. CAPACITY/HORSEPOWER

NP Hydraulic Size

SEC. 500

Page 99

January 2010

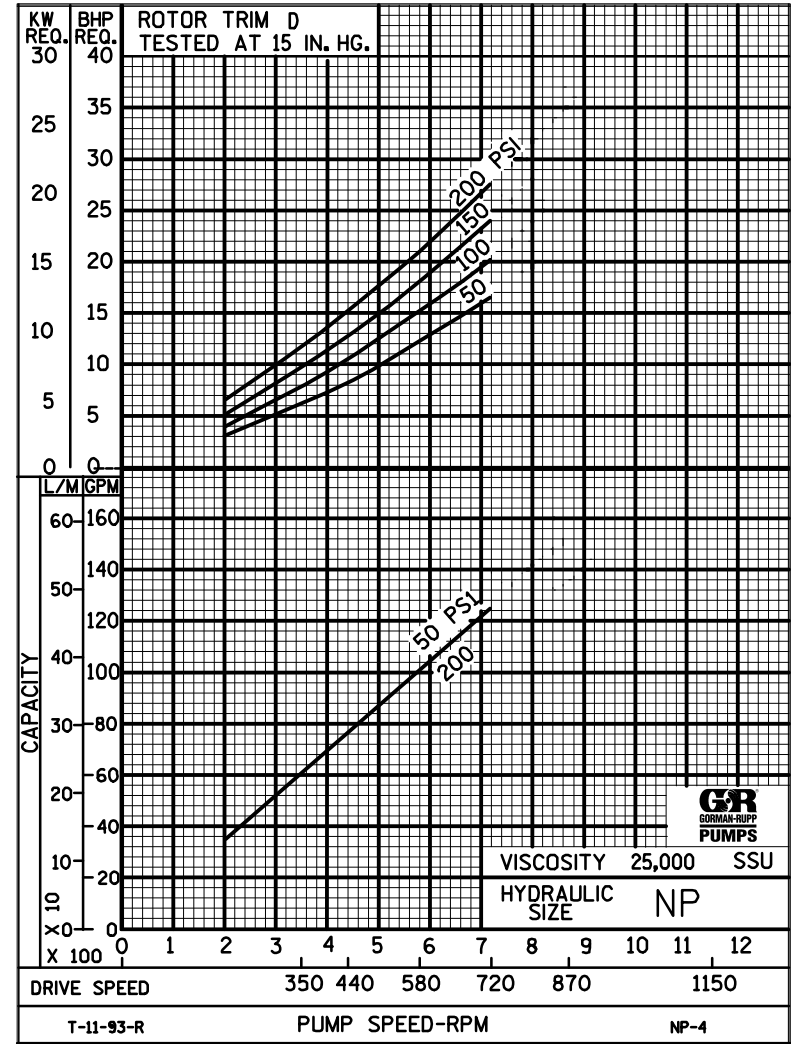
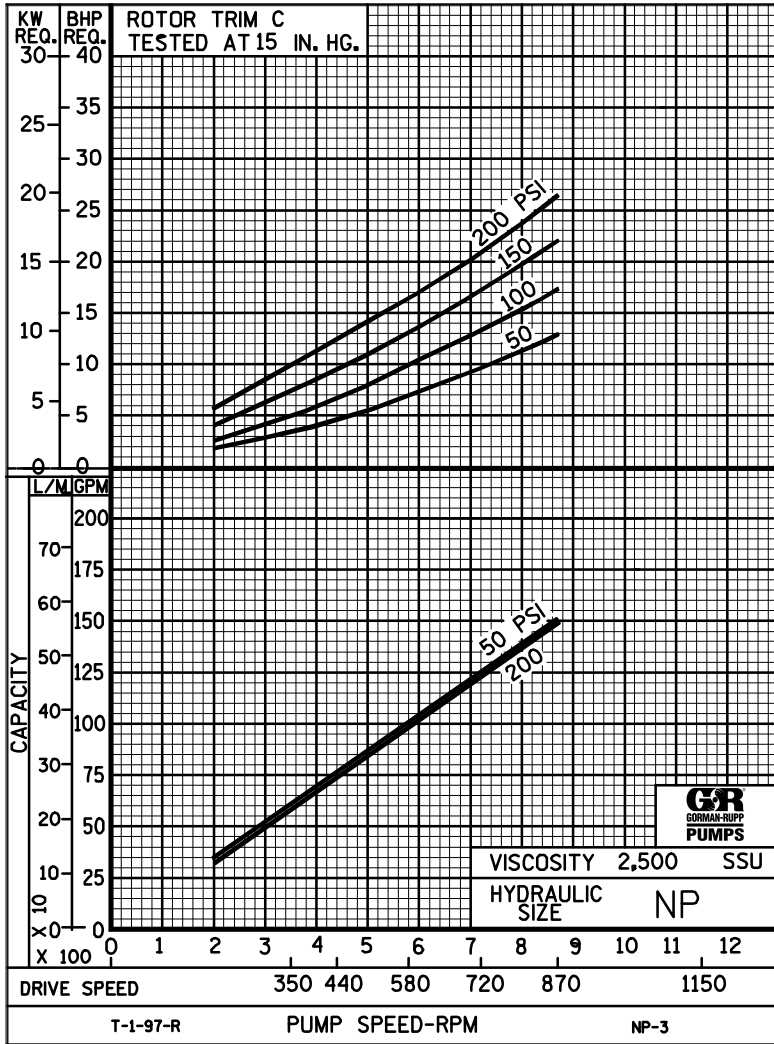

THE GORMAN-RUPP COMPANY • MANSFIELD, OHIO
 GORMAN-RUPP OF CANADA LIMITED • ST. THOMAS, ONTARIO, CANADA

Printed in U.S.A.

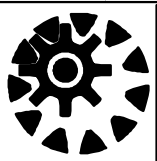

NP

PUMP HYDRAULIC SIZE CHART

SEC. 500

Page 100

January 2010

150 GPM
870 RPM

NOMINAL		ROTOR TRIM	VISCOSITY (SSU)	N.I.P.R. (PSIA)	FRICTION PIPE LOSS (PSI/FT) (Based on Sch 40 Steel Pipe)					FULL BYPASS RELIEF VALVE PRESSURE (PSI)					CAPACITY (GPM) / H.P. REQUIRED																																								
CAP. GPM	SPEED RPM				PIPE DIAMETER					CRACKING PRESS. (PSI)					DIFFERENTIAL PRESSURE (PSI)																																								
					2"	2 1/2"	3"	4"	5"	LOW PRES R/V			HI PRES R/V		25	50	75	100	150	200	300	400	MEDIUM DUTY AND HEAVY DUTY				HEAVY DUTY ONLY																												
150	870	STD	28	4.2	.01	.01	.01	.01	.01	68	96	125			144	143	141	140																																					
			32		.13	.06	.02	.01	.01						5.3	7.4	9.6	12																																					
			38	4.2	.16	.07	.03	.01	.01	68	96	125	168			145	144	143	142	141																																			
			50		.19	.08	.03	.01	.01							5.5	7.6	9.8	12	17																																			
			70	4.2	.22	.09	.04	.01	.01	70	100	128	170	223			148	147	146	145	144	143																																	
			100		.24	.11	.04	.01	.01								6.0	8.0	10	13	17	21																																	
			150	4.2	.27	.12	.04	.01	.01	72	102	131	172	226			149	149	148	147	146	146																																	
			200		.30	.13	.05	.01	.01								6.9	8.7	11	13	18	22																																	
			300	4.2	.34	.15	.05	.01	.01	74	104	134	174	230			150	150	149	149	148	147																																	
			500		.39	.15	.05	.02	.01								7.9	9.6	12	14	19	23																																	
			750	4.2	.39	.19	.08	.03	.01	76	106	137	178	232			151	151	151	150	150	150																																	
			1,000		.49	.24	.10	.04	.02								8.9	11	13	15	20	24																																	
		2,000	5.8	.97	.48	.20	.07	.03	90	122	154	196	248			151	151	151	151	150	150																																		
		3,500		1.69	.83	.35	.12	.05								11	14	16	18	23	28																																		
		5,000	6.9	2.42	1.19	.50	.17	.07	100	134	168	208	262			151	151	151	151	150	150																																		
		7,500		3.63	1.78	.75	.25	.10								14	16	18	20	25	30																																		
		10,000	8.2	4.83	2.38	1.00	.34	.14	110	144	180	222	275			151	151	151	151	150	150																																		
		15,000		7.25	3.56	1.50	.51	.21								17	19	21	23	28	32																																		
		20,000																																																					
		25,000																																																					
50,000																																																							
75,000																																																							
100,000																																																							
150,000																																																							
200,000																																																							
250,000																																																							

(NOTE) For speeds not shown on the pump hydraulic charts, consult factory.



NP

PUMP HYDRAULIC SIZE CHART

SEC. 500

Page 101

January 2010

**99 GPM
580 RPM**

NOMINAL		ROTOR TRIM	VISCOSITY (SSU)	N.I.P.R. (PSIA)	FRICTION PIPE LOSS (PSI/FT) <small>(Based on Sch 40 Steel Pipe)</small>					FULL BYPASS RELIEF VALVE PRESSURE (PSI)					CAPACITY (GPM) / H.P. REQUIRED															
CAP. GPM	SPEED RPM				PIPE DIAMETER					CRACKING PRESS. (PSI)					DIFFERENTIAL PRESSURE (PSI)															
					2"	2 1/2"	3"	4"	5"	LOW PRES R/V			HI PRES R/V		25	50	75	100	150	200	300	400								
							50	75	100	150	200	MEDIUM DUTY AND HEAVY DUTY				HEAVY DUTY ONLY														
99	580	STD	28	2.5	.01	.01	.01	.01	.01	62	88	118			95	92	91	90												
			32		.06	.03	.01	.01	.01								3.2	4.6	6.2	7.8										
			38	2.5	.08	.03	.01	.01	.01	62	88	118	164				96	94	94	93	92									
			50		.09	.04	.02	.01	.01								3.2	4.7	6.3	7.9	11									
			70	2.5	.11	.05	.02	.01	.01	64	90	120	164	210			98	97	96	96	95	94								
			100		.12	.05	.02	.01	.01								3.3	4.7	6.4	8.0	11	14								
			150	2.5	.14	.06	.02	.01	.01	64	92	120	168	214			99	99	98	98	97	96								
			200		.15	.06	.03	.01	.01								3.5	4.9	6.5	8.1	11	14								
			300	2.5	.17	.06	.03	.01	.01	66	94	122	168	218			100	99	99	99	98	98								
			500		.17	.08	.04	.01	.01								4.0	5.1	6.8	8.2	11	15								
			750	2.5	.24	.12	.05	.02	.01	68	96	122	172	222			101	101	101	100	99	99								
			1,000		.32	.16	.07	.02	.01								4.5	5.9	7.1	8.9	12	15								
		2,000	3.2	.64	.32	.13	.05	.02	74	102	128	180	230			101	101	101	100	100	99									
		3,500		1.12	.55	.23	.08	.03								5.9	7.3	8.9	10	14	17									
		5,000	3.8	1.60	.79	.33	.11	.05	76	104	130	184	234			101	101	101	100	100	100									
		7,500		2.39	1.18	.50	.17	.07								7.1	9.0	10	12	15	18									
		10,000	4.5	3.19	1.57	.66	.22	.09	78	106	132	188	236			101	101	101	100	100	100									
		15,000		4.79	2.35	.99	.33	.14								8.9	11	13	14	17	20									
		20,000	5.2	6.38	3.14	1.32	.45	.18	80	108	134	192	240			101	101	101	100	100	100									
		25,000		7.97	3.92	1.64	.56	.23								11	12	14	15	18	21									
		50,000	9.0	16.0	7.83	3.29	1.11	.45	88	120	146	208	250			101	101	101	100	100	100									
		75,000		23.9	11.8	4.93	1.66	.68								17	23	25	27	30	33									
		100,000																												
		150,000																												
		200,000																												
250,000																														

(NOTE) For speeds not shown on the pump hydraulic charts, consult factory.



NP

PUMP HYDRAULIC SIZE CHART

SEC. 500

Page 102

January 2010

**60 GPM
350 RPM**

NOMINAL		ROTOR TRIM	VISCOSITY (SSU)	N.I.P.R. (PSIA)	FRICTION PIPE LOSS (PSI/FT) <small>(Based on Sch 40 Steel Pipe)</small>					FULL BYPASS RELIEF VALVE PRESSURE (PSI)					CAPACITY (GPM) / H.P. REQUIRED												
CAP. GPM	SPEED RPM				PIPE DIAMETER	CRACKING PRESS. (PSI)		DIFFERENTIAL PRESSURE (PSI)																			
		LOW PRES R/V	HI PRES R/V	MEDIUM DUTY AND HEAVY DUTY				HEAVY DUTY ONLY																			
		2"	2 1/2"	3"	4"	5"	50	75	100	150	200	25	50	75	100	150	200	300	400								
60	350	STD	28	1.5	.01	.01	.01	.01	.01	57	83	107			55	55	53	52									
			32		.02	.01	.01	.01	.01							1.8	2.7	3.8	4.8								
			38	1.5	.03	.02	.01	.01	.01	57	83	107	157			56	56	55	54	53							
			50		.04	.02	.01	.01	.01							1.9	2.8	3.9	4.9	6.7							
			70	1.5	.05	.02	.01	.01	.01	58	85	109	157	210		58	58	57	57	56	55						
			100		.05	.02	.01	.01	.01							2.0	2.9	3.9	4.9	6.8	8.8						
			150	1.5	.06	.03	.01	.01	.01	58	85	109	157	210		60	60	59	59	58	57						
			200		.06	.03	.01	.01	.01							2.1	3.0	4.0	5.0	6.9	8.9						
			300	1.5	.06	.03	.01	.01	.01	59	87	112	159	212		61	60	60	60	59	59						
			500		.10	.05	.02	.01	.01							2.2	3.1	4.1	5.0	6.9	9.0						
		750	1.5	.15	.07	.03	.01	.01	59	87	112	159	212		61	60	60	60	60	60							
		1,000		.20	.10	.04	.02	.01							2.3	3.3	4.2	5.0	7.0	9.1							
		2,000	2.1	.39	.19	.08	.03	.01	63	90	117	170	219		61	60	60	60	60	60							
		3,500		.68	.33	.14	.05	.02							3.0	4.0	4.9	5.7	7.6	9.6							
		5,000	2.5	.97	.48	.20	.07	.03	64	90	117	170	219		61	60	60	60	60.3	60							
		7,500		1.45	.71	.30	.10	.04							3.6	4.6	5.0	6.3	8.2	10							
		10,000	3.1	1.93	.95	.40	.14	.06	65	92	120	174	225		61	60	60	60	60	60							
		15,000		2.90	1.43	.60	.20	.08							4.4	5.4	6.2	7.0	8.9	11							
		20,000	3.6	3.87	1.90	.80	.27	.11	65	92	120	174	225		61	60	60	60	60	60							
		25,000		4.83	2.37	1.00	.34	.14							5.1	6.0	7.0	7.9	9.7	12							
50,000	6.5	9.66	4.75	1.99	.67	.27	70	98	126	179	232		61	60	60	60	60	60									
75,000		14.5	7.12	2.99	1.01	.41							7.5	8.5	9.5	11	12	14									
100,000	10.2	19.3	9.49	3.98	1.35	.55	75	104	132	185	238		61	60	60	60	60	60									
150,000		29.0	14.3	5.97	2.02	.82							10	11	13	15	17	20									
200,000																											
250,000																											

(NOTE) For speeds not shown on the pump hydraulic charts, consult factory.